

DESCRIPTION

The LT-MP Power End Termination Kit is for use with all versions of Nelson Heat Tracing Systems' LT, CLT, HLT and NC heater cables. Compatible for use with any vendor's heater cables smaller than 11mm (0.44") diameter.

KIT CONTENTS

- 5 Power Terminations
- 1 Tube of Silicone

OVERJACKET PRODUCTS

For Braided Products proceed to step 4 below.

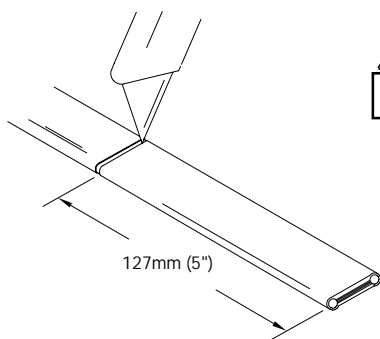

⚠ WARNING:
DO NOT CUT BRAID

- 1 Lightly cut around heater overjacket 127mm (5") from the end. Bend cable to break the overjacket.
- 2 Lightly cut overjacket up the center between first cut mark and the cable end. Bend cable to break the overjacket.

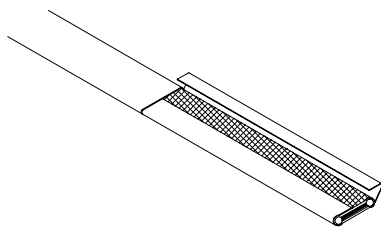

- 3 Remove overjacket from heater cable.

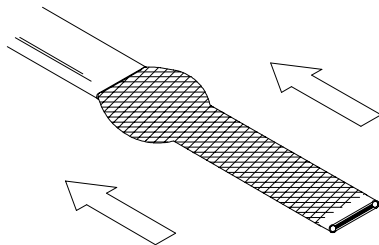

- 4 Move braid back toward the overjacket, creating a bulge.

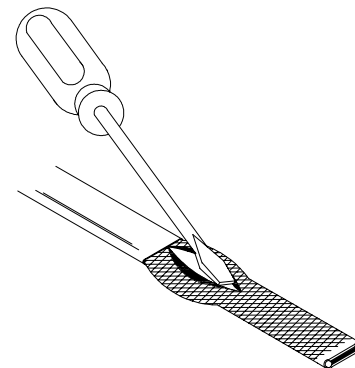

- 5 At the bulge, separate the braid to make an opening.

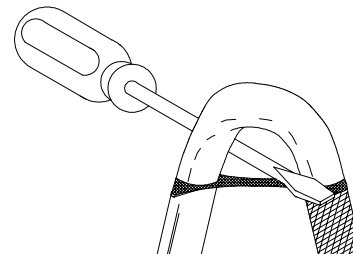

- 6 While bending the heater cable, work it through the braid opening.

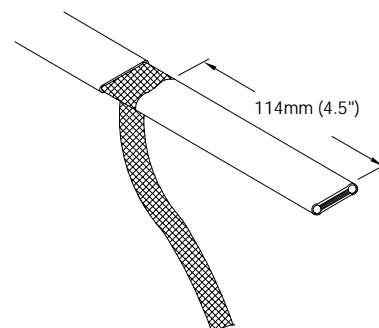

- 7 Pull the braid tight.
- 8 Proceed to "LT, CLT & HLT Products", sheet 2.

FOR ALL NELSON LT, CLT & HLT PRODUCTS

(See sheet 3 for an alternate method of HLT products.)

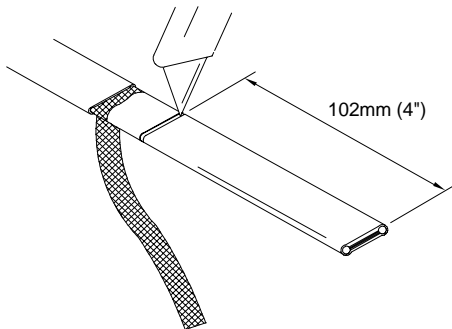

- 1 Lightly cut around cable outer jacket 102mm (4") from the end. Bend cable to break outer jacket.
- 2 Lightly cut the outer jacket up the center between the first cut mark & the cable end. Bend cable to break outer jacket.

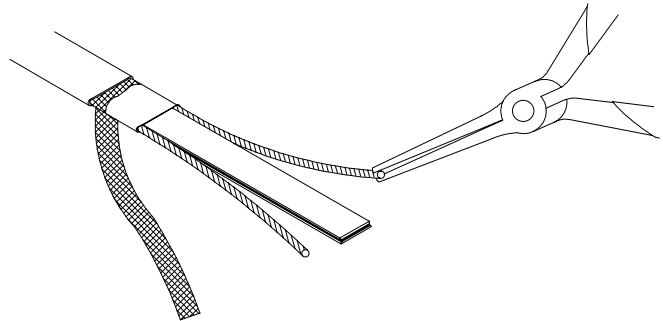

- 5 Starting at the end, pull each bus wire away from the core material.
- 6 Remove exposed core material.

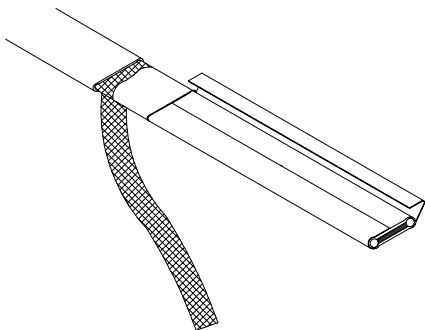

- 3 Remove the jacket from the heater cable.

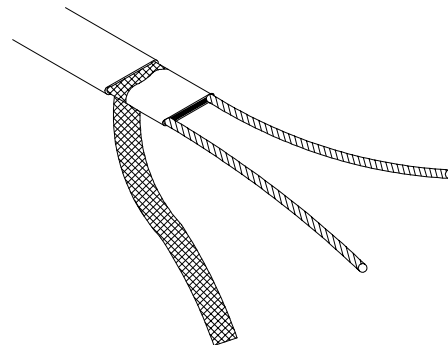

- 7 Cut 6mm (0.25") off the end of each bus wire.
- 8 Proceed to "Power Termination" on sheet 4.

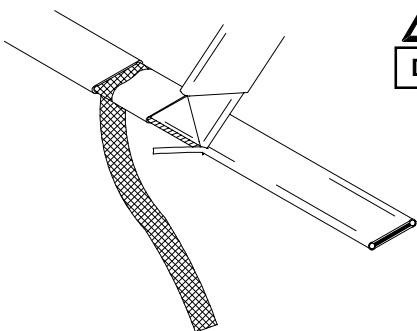

- 4 Shave the core material from the outside of each bus wire.

⚠ WARNING:
DO NOT CUT BUS WIRES

HLT PRODUCTS ALTERNATE STRIPPING METHOD

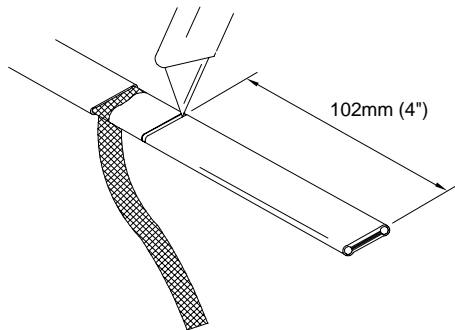

- 1 Lightly cut around cable outer jacket 102mm (4") from the end. Bend cable to break outer jacket.
- 2 Lightly cut the outer jacket up the center between the first cut mark & the cable end. Bend cable to break outer jacket.

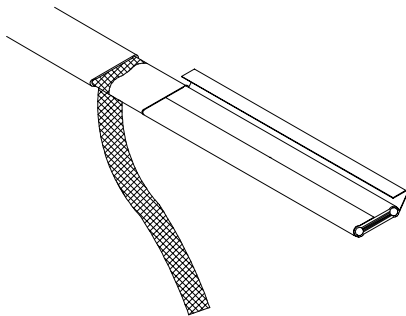

- 3 Remove the jacket from the heater cable.

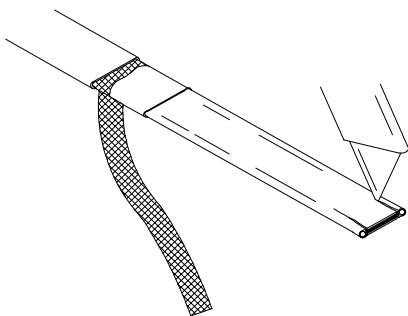

- 4 Make a cut inside each bus wire.

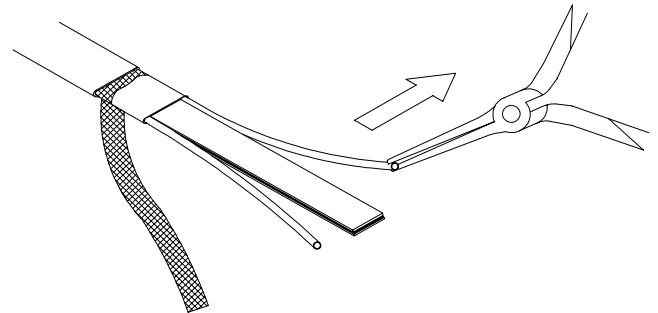

- 5 Starting at the end, in the same plane as the cable, pull each bus wire away from the core material.

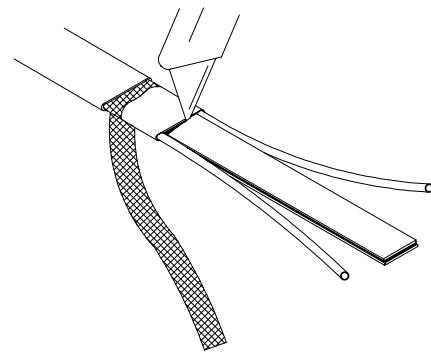

- 6 Remove the exposed core material.

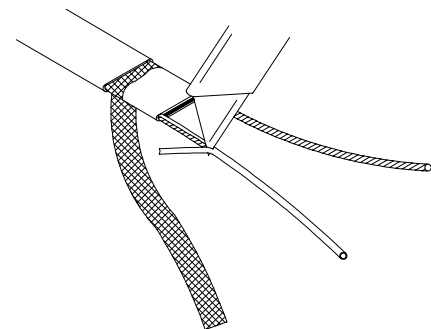

- 7 Remove the remaining core material off the outside of each bus wire.
- 8 Cut 6mm (0.25") off the end of each bus wire.
- 9 Proceed to "Power Termination" on sheet 4.

POWER TERMINATION

⚠ WARNING:

- Bus wires must not touch or cross while inserting into power termination.
- Only power terminations / end seals specifically approved for the vendors style and type of heater cable must be used.

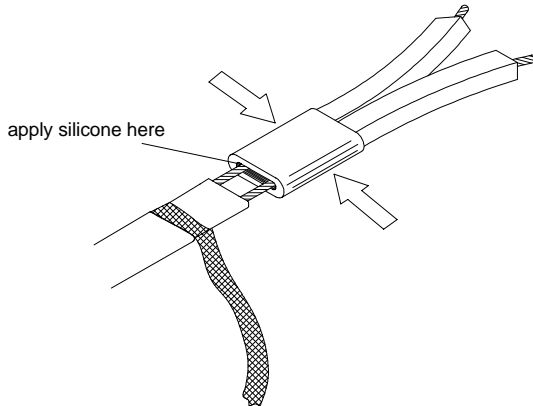

- 1 Insert bus wires into power termination.
- 2 Squeeze power termination opening and fill with silicone.

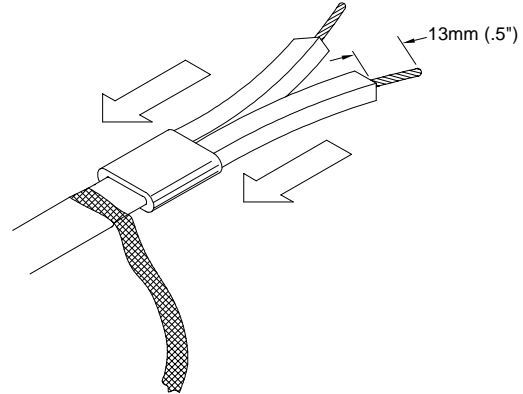

- 3 Push power termination to overlap jacket.
- 4 The silicone will set up in about 30 minutes with a complete cure after 24 hours.

⚠ WARNING:

- Do not megger or hi-pot until silicone is completely cured.
- Braid must be kept away from bus wires or shorting will occur.