

HeatTape^{PRO}

INSTALLATION MANUAL



SCAN THIS CODE



FOR THE LATEST VERSION OF
OUR MANUAL

R RADIANT SOLUTIONS COMPANY

Plug-In Self-Regulating Heating Cables

Please read and save these instructions. Read carefully before attempting to assemble, install, operate or maintain the product described. Protect yourself and others by observing all safety information. Failure to comply with instructions could result in personal injury and/or property damage! Retain instructions for future reference. The guidelines detailed herein need to be followed to ensure warranty coverage.



Pipe Heating Cable
E330224
Parallel - W



DE-ICING AND SNOW
MELTING EQUIPMENT
E482897
Parallel - WS

W: With wet rating

WS: With wet test and weather resistance

QUESTIONS?

CALL US: 1-877-387-4218

OR VISIT: radiantsolutionscompany.com

TABLE OF CONTENTS

1.0 Warnings	1
1.1 General Information	2
1.2 Cable Specifications	2
1.3 Maximum Allowable Cable Lengths on Circuits	3
1.4 Wattage Charts for Pre-Assembled Cables	3
1.5 GlowCap	3
1.6 Safeguards & Warnings	4
1.7 Cable Length Calculation Chart	5
1.8 Cable Testing and Maintenance	5
1.9 Gutters, Downspouts and Cable Length Calculations	5
2.0 Valleys and Heat Cable Planning	5
2.1 Installing Heat Cable on Roof with Gutters	6
2.2 Installing Heat Cable on Roof without Gutters	7
2.3 Installing Grip Clips	8
2.4 Installing Heat Cable on Roofs	9
2.5 Installation Ideas: Other Accessories and Methods	10
2.6 Installation Diagrams	11
2.7 Pipe Freeze Protection Heating Cable Selection	12
2.8 Pipe Freeze Protection Heating Cable Installation	12
2.9 Pipe Freeze Protection Thermal Insulation Installation	12
3.0 Pipe Freeze Protection Thermal Insulation Continued	13
3.1 Pipe Freeze Protection : Additional Install Diagram	13
3.2 Installation Accessories	14
3.3 Warranty	15
3.4 Troubleshooting Guide	16
3.5 Project Drawing Pad	17

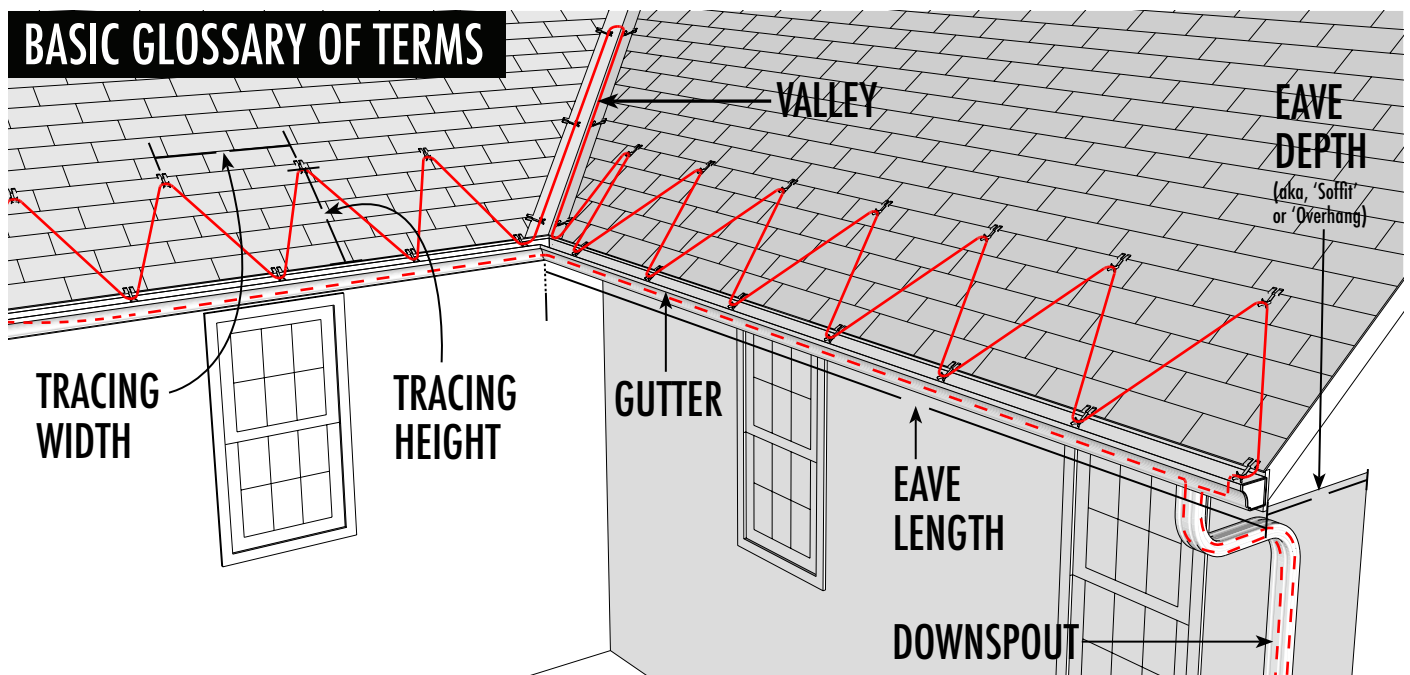

HeatTape PRO

1.0 WARNINGS

WARNING

The maximum size of the branch circuit shall not be less than 125% of the ampere load of the cable installed

AVERTISSEMENT

La taille maximale du circuit de dérivation ne doit pas être inférieure à 125 % de la charge en ampères du câble installé.

WARNINGS

This product must be installed by a qualified person in accordance with this installation handbook and with the National Electric Code (U.S.) as applicable. All electric connections must be made by a qualified electrician, according to the electrical and building codes effective in your region.

AVERTISSEMENT

Ce produit doit être installé par une personne qualifiée conformément au présent manuel d'installation. Tous les raccordements électriques doivent être effectués par un électricien qualifié, conformément aux codes de l'électricité et du bâtiment en vigueur dans votre région.

WARNINGS

Two copies of a caution notice indicating the presence of electric de-icing and snow-melting equipment on the premises are packed with this unit. One notice must be posted at the fuse or circuit-breaker panel and the other on or next to the on/off control for the cable unit. Both notices must be clearly visible

AVERTISSEMENT

Deux exemplaires d'un avis de mise en garde indiquant la présence d'équipement de dégivrage électrique et de fonte de neige sur les lieux sont emballés avec cet appareil. Un avis doit être affiché au niveau du panneau de fusibles ou de disjoncteurs et l'autre sur ou à côté de la commande marche/arrêt du câble. Les deux avis doivent être clairement visibles.

WARNINGS

Do not use damaged heating cables, power cord or plug. Remove and replace immediately to prevent a fire, shock or arcing hazard.

AVERTISSEMENT

Ne pas utiliser de câbles de chauffage, de cordon d'alimentation ou de fiche endommagés. Retirer et remplacer immédiatement pour éviter tout risque d'incendie, de choc ou d'arc électrique.

WARNINGS

Keep ends of heating devices and kit components dry before and during installation

AVERTISSEMENT

Garder les extrémités des appareils de chauffage et l'ensemble des composants au sec avant et pendant l'installation.

WARNINGS

The conductive layer of this heating device must be connected to a suitable grounding/earthing terminal.

AVERTISSEMENT

La couche conductrice de ce dispositif de chauffage doit être connectée à une borne de terre/terre appropriée.

WARNINGS

Never attempt to pull the heating cable tight or create tension in the heat cable system from one clip to the next as this will put unnecessary stress on the roof clips and the cable over time. The cable should be loosely laid on the roof with just enough tension to maintain the proper serpentine pattern and keep the heat cable stable in the roof clips.

AVERTISSEMENT

Ne tentez jamais de serrer le câble de chauffage ou de créer une tension dans le système de câbles de chauffage d'une pince à la suivante, car cela exercera une pression inutile sur les attaches de toit et le câble au fil du temps. Le câble doit être lâchement posé sur le toit avec juste assez de tension pour maintenir le bon motif de serpentine et garder le câble de chaleur stable dans les clips de toit.

WARNINGS

SHOCK AND FIRE HAZARD. If the cable system is not installed properly and/or damaged, fire or shock can occur and can result in serious personal injury or damage to property.

AVERTISSEMENT

RISQUE DE CHOC ET D'INCENDIE. Si le système de câbles n'est pas installé correctement et/ou endommagé, un incendie ou un choc peut se produire et entraîner des blessures graves ou des dommages matériels.

WARNINGS

De-energize all power circuits before installation or servicing

AVERTISSEMENT

Mettre hors tension tous les circuits d'alimentation avant l'installation ou la maintenance.

WARNINGS

The presence of the heating devices shall be made evident by the posting of caution signs or markings where clearly visible.

AVERTISSEMENT

La présence des dispositifs de chauffage doit être mise en évidence par l'apposition de panneaux de mise en garde ou de marques bien visibles.

HeatTape PRO

This guide describes the Radiant Solutions Company Plug-In Self-Regulating Heat Tape Pro Cables and how to install the system. It is important to review this guide. For additional information regarding any aspect of this product, contact Radiant Solutions Company.

1.1 GENERAL INFORMATION

Heat Tape Pro self-regulating heat cables are designed to be used for a variety of roof de-icing, gutter de-icing and pipe freeze applications. Self-regulating heat cable automatically calls for more energy when ambient outdoor temperatures are lower and conversely, less energy when outdoor temperatures are higher. Heat Tape Pro is pre-terminated in our factory for your safety and convenience. No field modifications will be necessary to the cable to use it for the described purposes.

Heat Tape Pro self-regulating heat cables are approved for use on all common roofing materials (both sloped and flat) including asphalt shingles, wood shakes and shingles, synthetic shakes and slate, membranes such as EPDM and TPO, tile, concrete tiles, tar, slate and metal as well as gutters made of both metal and plastic. Heat Tape Pro can be used for pipe freeze applications on all common pipe materials including copper, PEX, PVC, ABS and galvanized.

1.2 CABLE SPECIFICATIONS

Cable Construction:	Self-regulating
Rated Voltage:	120V, 208V-240V
Output at 50°F (10°C) :	6.0 Watts per foot on pipe
Output at 32°F (0°C) :	6.0 Watts per foot in air
Lengths:	6 ft to 150 ft
Bending radius (min.):	0.8 in @ 5°F (-15°C)
Cable Dimensions:	6 mm Thick x 12 mm Wide
Min. Circuit Size:	15 amp
Max. Exposure Temp*:	185°F (85°C)
Min. Install Temp:	5°F (-15°C)
Power Cord:	120" 3-wire 14 AWG + Lit plug
Bus Wires:	16 Gauge AWG (A)
Conductor Insulation:	Self-Regulating Conductive Core (B)
Inner Jacket:	Modified Polyolefin (C)
Braid:	Tinned Copper (D)
Outer Jacket:	TPE (E)
Utility Hole:	6mm (F)
LED Indicator:	100,000 Hour Duty Cycle (G)

*This is the maximum temperature the cable should be exposed to for extended periods of time. Prolonged exposure to higher temperatures may cause premature cable degradation.



Heat Tape Pro self-regulating heat cable has an optional, factory-installed 'GlowCap' end seal, which is an injection molded termination with a green LED. The GlowCap allows users to determine if either of the two main 16AWG buss wires has been severed. If one of the buss wires has been severed, the green indicator light will NOT illuminate and the cable will not heat up. The GlowCap also features a utility hole that can be used in conjunction with a cable tie to secure the end of the cable off the bottom of the gutter to prevent longterm submersion in standing water. See Section 1.5 for details. Do not apply pull force when using the utility hole in order to prevent damage to the end cap. As with end seals on all Heat Tape Pro cables, do not allow the GlowCap to be exposed to long-term submersion.

HeatTape PRO

1.3 MAXIMUM ALLOWABLE CABLE LENGTHS PER CIRCUIT BREAKER

This chart displays the number of feet of Heat Tape Pro that can be installed on given circuit and the amperage draw at different start-up temperatures. The colder the outdoor temperatures, the more amps the cable demands. For example, in the chart (right), you can install up to 150 feet of 120 volt Heat Tape Pro cable on a 15 amp circuit without tripping that circuit when the system is turned on at 32°F or warmer.

Heat Tape Pro Cable Start-Up Temperature		120V 15 Amp
50°F	10°C	175 Ft
32°F	0°C	150 Ft
-0°F	-18°C	113 Ft
-20°F	-29°C	99 Ft
-40°F	-40°C	88 Ft

1.4 120 VOLT PRE-ASSEMBLED CABLE WATTAGE CHARTS

These charts display the watts consumed per 120 volt Heat Tape Pro cable according to length. The charts provide data for wattage draw on both roof and gutter de-icing and pipe freeze protection applications.

Start Up Temperatures:

We strongly recommend that you energize your heat cable system before temperatures drop below 32°F because self-regulating heat cable demands more power at lower temperatures. Under certain circumstances (such as with longer cable lengths) a heat cable system can trip circuits at low start-up temperatures because the wattage demand 'spikes' when the system is energized.

Roof & Gutter De-Icing Watt Chart @ 32°F

Length	Air	In ice/Snow
6 ft	36W	72W
12 ft	72W	144W
18 ft	108W	216W
24 ft	144W	288W
37 ft	222W	444W
50 ft	300W	600W
62 ft	372W	744W
75 ft	450W	900W
87 ft	522W	1044W
100 ft	600W	1200W
112 ft	672W	1344W
125 ft	750W	1500W
137 ft	822W	1644W
150 ft	900W	1800W

Pipe Freeze Protection Watt Chart @ 50°F

Length	Air	On Pipe
6 ft	30W	36W
12 ft	60W	72W
18 ft	90W	108W
24 ft	120W	144W
37 ft	185W	222W
50 ft	250W	300W
62 ft	310W	372W
75 ft	375W	450W
87 ft	435W	522W
100 ft	500W	600W
112 ft	560W	672W
125 ft	625W	750W
137 ft	685W	822W
150 ft	750W	900W

1.5 GLOWCAP DETAILS

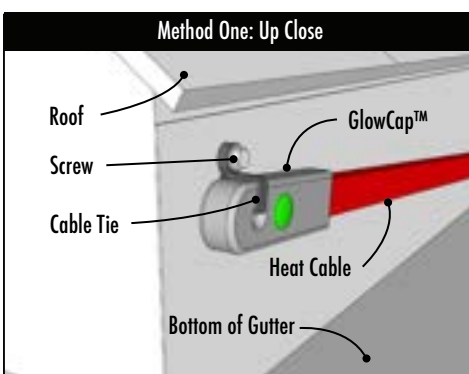

We suggest that you keep the GlowCap™ off the bottom of the gutter using one of the approaches, left. Method One employs a screw-mount cable tie, which secures the GlowCap directly to the back wall of the gutter with a self-tapping sheet metal screw. Method Two illustrates how to hang the GlowCap™ from a gutter bracket using a standard cable tie. You may also choose to place the GlowCap™ over the edge of the gutter or on the roof itself to allow it to be seen from the ground. This allows you to monitor your cable with ease by simply looking for the green indicator light.

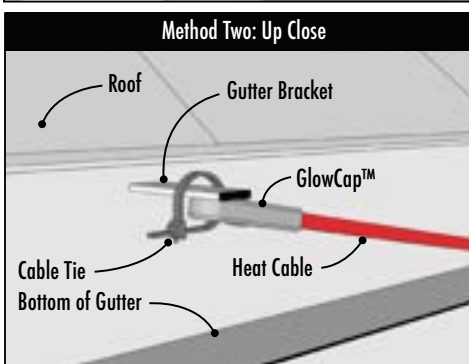

You can place the GlowCap™ at the end of the Heat Tape Pro cable in an area that is visible in order to quickly see that your cable is energized. Use a long cable tie to secure the GlowCap™ as shown, right, where it exits a downspout. For added protection, use a Cable Guard to protect the area of cable that is exposed.



HeatTape PRO

1.6 SAFEGUARDS AND WARNINGS

Read and understand all instructions in this manual and Safety Warnings. Electrical cables can present a fire, shock and arcing hazard if they are damaged or are not installed correctly. Additional guidelines:

1. Do not use extension cords.
2. 30-mA ground fault protection of equipment is required for each heating cable branch circuit for maximum protection, especially for fixed outdoor electric de-icing and snow-melting equipment.
3. Before installing or servicing cable, ensure that all power to supply circuit(s) is OFF.
4. Do not twist cable during installation.
5. On roof de-icing applications, do not install cable under roofing materials.
6. Do not expose cable to temperatures above 185°F (85°C), as this will damage the cable.
7. Installation must be in compliance with National Electrical Codes (NEC).
8. On pipe freeze applications, use only fire-resistant insulation, such as preformed foam. Do not embed heating cable in spray foam insulation.
9. On pipe freeze applications, use 1/2" to 1" fiberglass tape or plastic cable ties when attaching cable to pipe. Do not use wire or metal clamps.
10. Heat Tape Pro is designed to create ice-free pathways, not prevent accumulated snow or ice in large areas adjacent to cables.
11. For the warranty to be valid, the installer must comply with the requirements outlined in this manual.
12. Do not cut or attempt to alter the length of the cable as this may result in electrical shorting and shock.
13. Protect all cable that protrudes past the lower opening of all downspouts.
14. Use only watertight construction or enclosure Type 3, 3S, 4, 4X, 6, or 6P junction box when installing.
15. The conductive layer of this heating device must be connected to a suitable grounding/earthing terminal.
16. We recommend that you turn your heat cable on before temperatures drop below 32°F (0°C) or before any freezing precipitation occurs. This will reduce the likelihood of tripped circuits due to amperage spikes.
17. The presence of the heating devices shall be made evident by the posting of caution signs or markings where clearly visible.

NEVER

- Use fasteners such as nails, staples or screws to secure the cable to a surface (roof, gutter or pipe). Use approved clips only.
- Attempt to install the cable system if it is damaged.
- Install a cable that is energized (plugged in).
- Allow the sharp edge of a tool to nick or gouge into the cable.
- Use the heating cable for any purpose other than what is described in this manual.
- Install the heating cable under roofing material, in walls or in hidden areas.
- Install a cable designed for a 120V power source on a 240/208V power source.
- Exceed the maximum circuit lengths as this will result in breaker trips and will prevent the heating cable from turning on in freezing conditions.
- Install Heat Tape Pro self-regulating heat cable on surfaces or pipes that may exceed 150°F (85°C).
- Cut, slice or modify the heat cable as this can result in electrical shock or fire.
- Use Heat Tape Pro on pipes carrying anything other than water.
- Bend heat cable in a radius of less than 1".

ALWAYS

- Consult a roofing contractor in your area for recommendations on proper adhesives for roof material and environmental conditions.
- Ensure drip loops are made to prevent water from trailing into any electrical equipment, junction boxes and cable connections.
- Ensure gutters and downspouts are free of leaves and other debris prior to each winter season.
- Verify that the cable system is grounded and protected by GFCI technology.
- Ensure that this product is installed by a qualified person in accordance with this installation handbook and with the National Electric Code (U.S.) as applicable. All electric connections must be made by a qualified electrician, according to the electrical and building codes effective in your region.
- Perform testing and visual inspections of the heating cable after any type of roof maintenance or repairs including but not limited to roof/gutter/downspout repair, manual snow removal or installation or addition of roof features.
- Perform a bi-annual inspection of the cable system to determine if the cable is damaged and/or still operational.
- De-energize the cable system before the warm season (above 60°F)

HeatTape PRO

1.7 CABLE LENGTH CALCULATION CHART - BASIC

Eave Overhang	Tracing Width	Tracing Height	Cable per Ft. of Eave
>12"	24"	18"	2.0 Ft
12"	24"	18"	2.8 Ft
24"	24"	30"	3.8 Ft
36"	24"	42"	4.8 Ft
48"	24"	54"	5.8 Ft

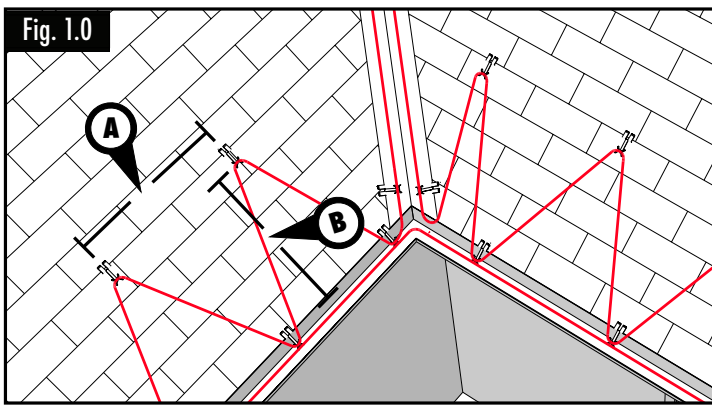

This chart provides general information on how much Heat Tape Pro cable you need for your application on standard shingle roofs. Most of our customers opt to use our handy online Heat Cable Calculator, but if you would like to approximate cable footage the old fashioned way, you can use this chart. For example, if your eave overhang is 24" the width between each tracing pattern (A), left, should be the standard 24" and the height from the bottom edge of the roof should be 30" (B), left. To calculate the footage required, you can multiply the feet of eave you are looking to cover by 3.8 feet. In other words, a 10' eave would require a cable length of 38'. This does not include valleys, gutters, downspouts or footage required for getting the cable to the power source. Applications involving other roofing systems, such as metal or rubber involve more variables than can be accounted for in a simple calculation. Please contact us directly for help in designing heat cable systems on these roof materials.

Table 1.0, left, shows tracing width (A) and tracing height (B). Standard tracing width for most installations is 24". Tracing height is determined by the depth of the eave. See Figure 18, page 9 for more details.

1.8 CABLE TESTING AND MAINTENANCE

Using a 1000vDC megohmmeter set to 1000 volts, check the resistance between both of the power prongs on the plug (together) and the ground prong both before and after installing the heating cable. The minimum reading should be 1000 megohms. If the readings fall below 1000 megohms, replace the cable with a new unit. Detecting cable damage prior to installation can prevent additional labor costs. Do not attempt to repair the cable. Record the original values for the original cable test for your warranty records and compare subsequent readings taken during regular maintenance to the original values. Testing should be performed yearly. A history of resistance readings can be useful in spotting moisture ingress into the cable.



Notes: Set megger to 1000v. Both prongs of plug need to be shorted together during test, as shown above.

1.9 GUTTERS, DOWNSPOUTS AND CABLE LENGTH CALCULATIONS

Add one foot of cable for every foot of standard residential gutter. Add two feet of cable per foot of large, commercial gutter to accommodate two cable runs inside the gutter. Add one foot of cable for every foot of downspout if the downspout is where the cable system begins or ends. If the downspout is in the middle of the cable system, add two feet of cable per foot of downspout to loop down and back up the downspout if necessary. In other words, double the length of the downspout to determine the footage of cable needed when the downspout is in the middle of the heat cable run.

2.0 VALLEYS AND HEAT CABLE PLANNING

We recommend running your heat cable a minimum of six feet up and down any valleys in your system. Generally speaking, steeper roof systems (i.e., 6/12 and up) require six feet or less. Lower pitch roofs (i.e., 2/12 through 5/12) may require more than six feet to provide adequate ice dam prevention coverage. Never drive nails within 6" of the center of the valley flashing to secure nail-on roof clips.

HeatTape PRO

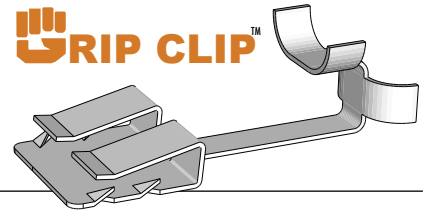

2.1 INSTALLING CABLE ON ROOF WITH GUTTER

Grip Clips are suitable for use with Heat Tape Pro on a variety of shingled roof systems including asphalt/composite, wood and synthetic. They allow for the installation of self-regulating heat cable on shingled roofs without the use of tools or nails driven through the roof. The installation time is approximately four times faster than traditional nail-on clips. Grip Clips allow the installation of heat cable near the center of the valley, which is difficult or impossible with traditional roof clips as they require nails be driven through the valley flashing (NCRA recommends nails not be driven within 6" of the centerline of the valley). Grip Clips can be removed without damaging the roofing materials using a putty knife to bend up the top arms of the clip.

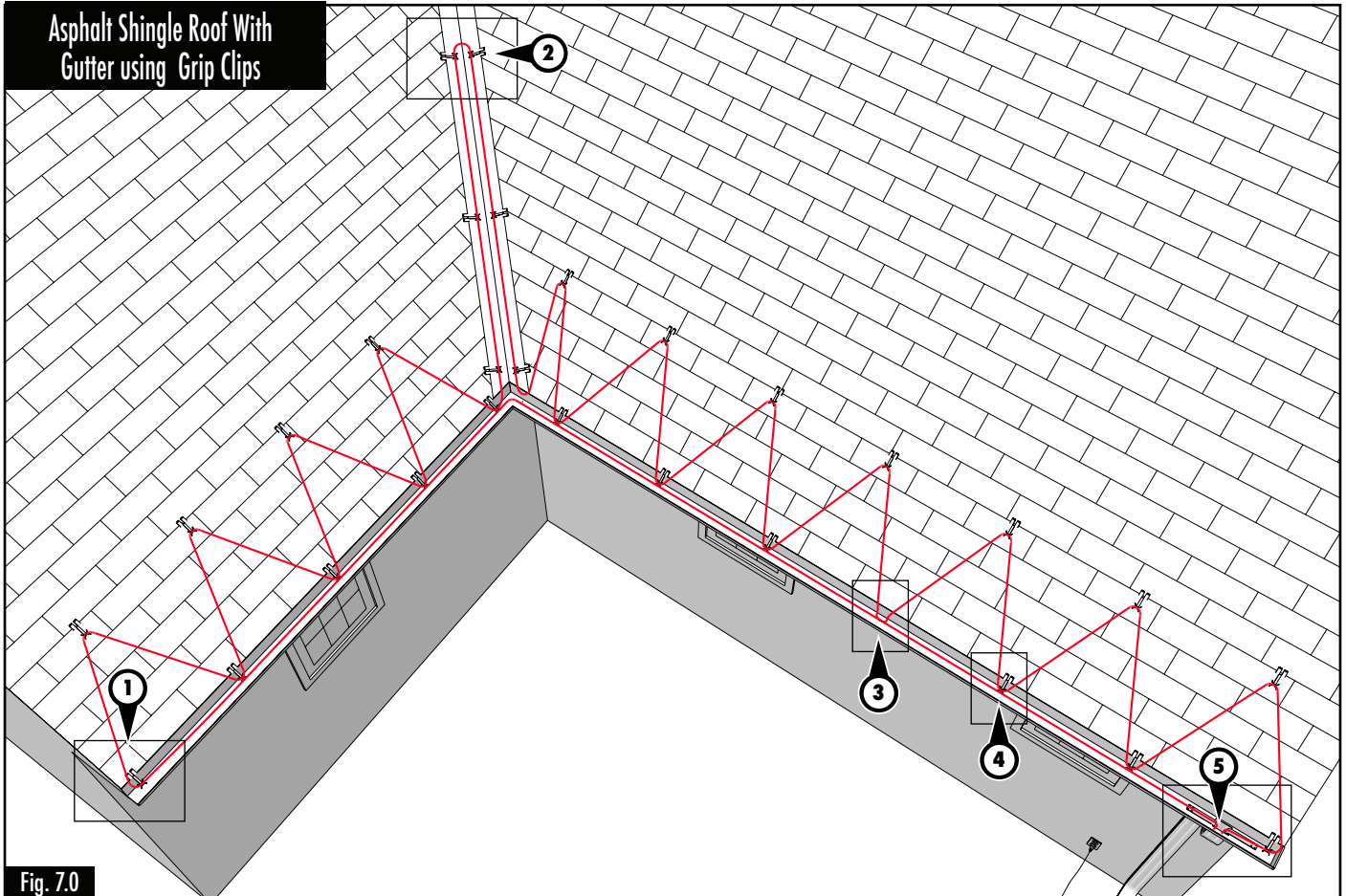

Fig. 7.0

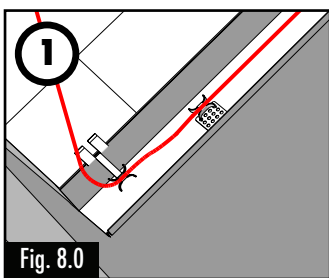

Fig. 8.0

Use a Grip Clip off the end of the last course of shingles to place the heating cable into the trough of the gutter. You may also use a traditional roof clip glued to the bottom of the gutter as shown here to secure the cable to the gutter or leave the cable unsecured altogether.

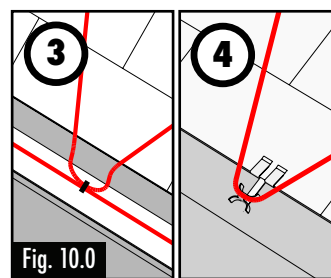

Fig. 10.0

An alternate method to using Grip Clips on the bottom edge of the shingle is to bend the cable down into the gutter and join it with a UV resistant cable tie to the heat cable running in the gutter.

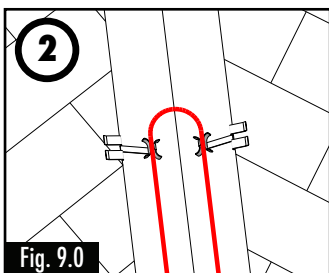

Fig. 9.0

Grip Clips allow for the installation of heat cable near the center of the valley flashing because no nails are required for installation. Install Grip Clips approximately every 36" up the valley. Running cable 72" up the valley is normally adequate.

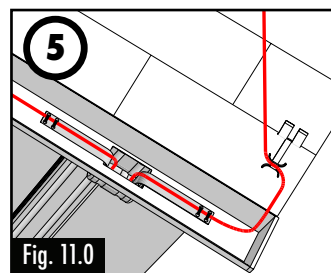
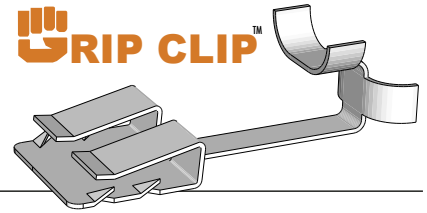

Fig. 11.0

Grip Clips can be used creatively to secure cable to the roof in any location. They can also be pushed onto the side of a shingle to run heat cable horizontally.

HeatTape PRO



2.2 INSTALLING CABLE ON ROOF WITHOUT GUTTER

Grip Clips can be used to install self-regulating heat cable on asphalt shingle roofs both with and without gutters. See clip installation manual for further details.

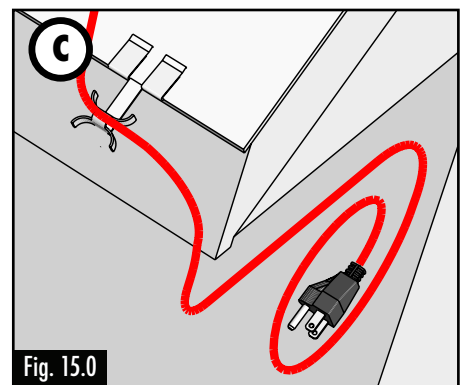
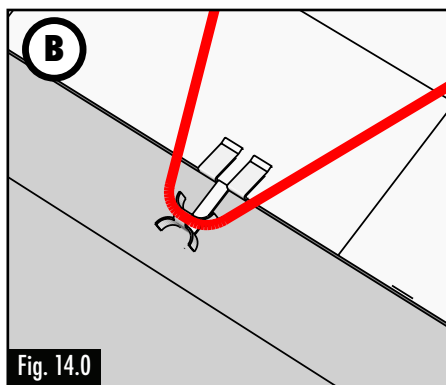
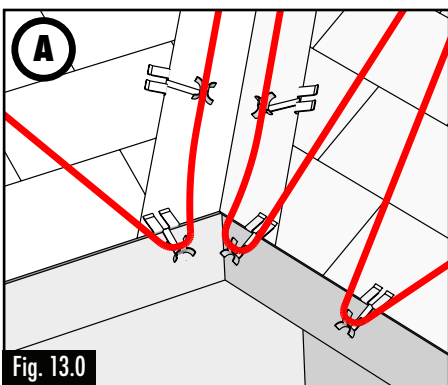
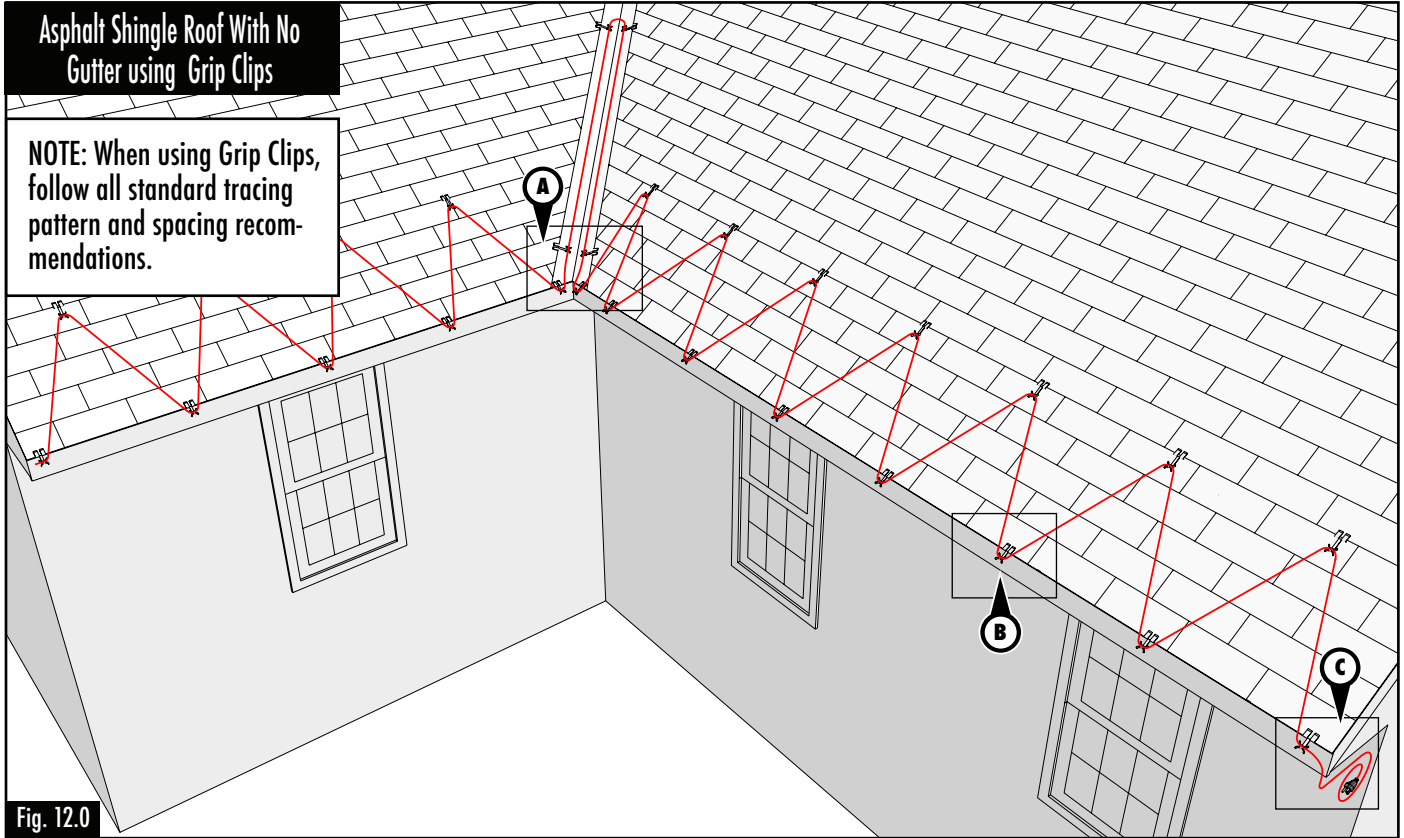

Grip Clips can be used on the end of valley flashing if there is a layer of ice & water membrane beneath the valley, as per certain building codes. If the Grip Clips are not stable when installed on the flashing as shown above, move the clips a couple inches to the left and right to mount them on the bottom edge of the adjacent roofing material.

When no gutters are present, install Grip Clips on the edge of the last shingle as shown. This creates a fixed drip loop by holding the heat cable off the edge of the roof, thus ensuring a continuous melted pathway through any accumulated ice. As with cable installations using traditional nail-on clips, the heating cable should not be pulled tight between the clips.

Use a Grip Clip off the end of the last course of shingles to place the heating cable in a position. The power cord on your Heat Tape Pro cable should be plugged directly into a dedicated outlet under the eave if possible.

HeatTape PRO

2.3 INSTALLING GRIP CLIPS

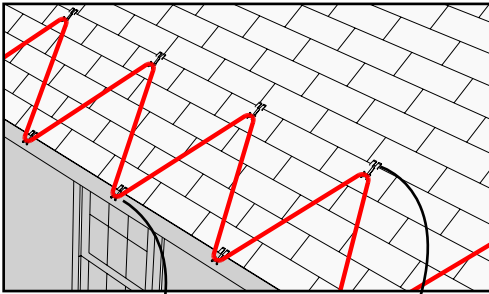

Grip Clips are the preferred heat cable clip for installations on shingled roof systems. Installations require NO tools and NO nails need to be driven into the roof. This greatly decreases installation time while also reducing the potential liability associated with using traditional nail-on clips. Grip Clips allow heat cables to be placed near the center of the valley which is impossible with nail-on roof clips due to nailing requirements. Additionally, Grip Clips can be easily repositioned or removed without damaging the roofing materials by simply bending up the top arms of the clip.

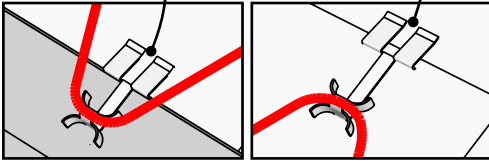

Uses:

The Grip Clip 325 can be used to install both self-regulating and constant wattage heat cable on asphalt shingle roofs on areas both with and without gutters. Use Grip Clip Models 625 and 875 for roofing materials between 3/8" and 3/4" thickness.

Grip Clip Installation Tips

1. To establish your Grip Clip locations, determine the best path for your cable pattern, factoring in variables such as downspout and power source locations. Some installers use chalk to mark clip locations prior to installation to ensure proper spacing.
2. Grip Clips can usually be installed by simply pushing the clip up onto the end of the asphalt shingle as shown in Drawings A and B, right. We recommend installing the Grip Clip on the double-thickness areas of dimensional asphalt shingles. If the glue strip between the asphalt shingles is quite bonded, use a putty knife as shown in Photo D to break the glue strip bond where you intend to insert your Grip Clip.
3. After the Grip Clip is pushed into position and is engaged into the asphalt shingle, lay the heat cable into the cradle area of the clip, as shown in Drawing C, and use your fingers to pinch the top half of the cradle down onto the cable.

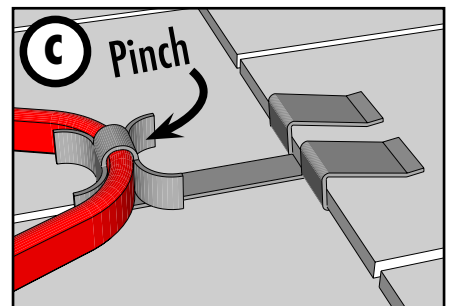
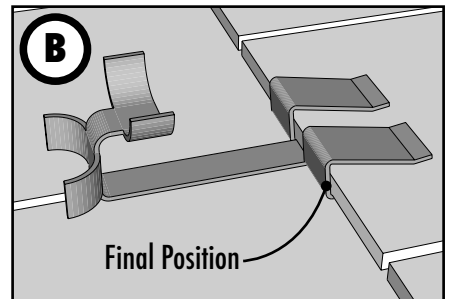
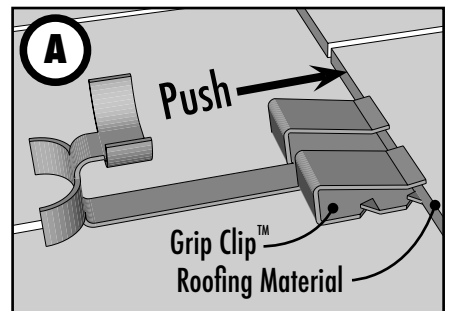

Considerations

There are four robust aluminium barbs on the bottom of each Grip Clip body. Those barbs embed, or 'bite', into the asphalt shingle creating a strong anchor that can be used for many years (Figure 1.0, Below). Installing the Grip Clip on cold roofing can prevent barb engagement. Therefore, we recommend performing the installation before the roofing material becomes cold and hard. If cool weather installations are necessary, barb engagement can be promoted by quickly warming the shingle with a heat gun in the clip location. Another technique is to simply wiggle the Grip Clip back and forth after it has been pushed up into position to encourage the barbs to sink into the asphalt shingle.

Grip Clips can be removed by simply prying up on the exposed arms until the pinching grip has been released from the shingle. The Grip Clip can then be safely slid off the shingle. Reusing Grip Clips that have been removed can be problematic because they may not 'bite' as well as new clips.

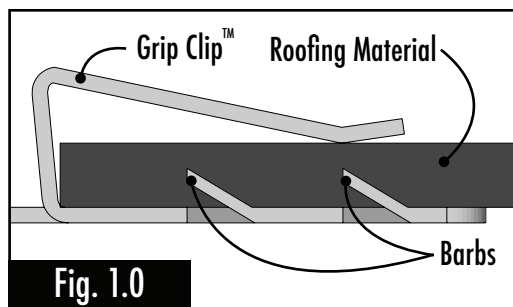

Fig. 1.0

HeatTape PRO

2.4 INSTALLING HEATING CABLE ON ROOFS

PREPARE FOR INSTALLATION

1. Plan your installation and double check your measurements to ensure you have chosen the right cable length for your application. Think through the best path for your cable pattern, factoring in variables such as downspout and power source locations. Some installers use chalk to mark out clip locations prior to clip installation to ensure proper spacing.
2. Before installing Heat Tape Pro, make sure the roof, gutters and downspouts are free of debris or any combustibles.
3. Check the cable prior to installation for any signs of mechanical damage such as cuts or gouges through the outer jacketing.
4. After uncoiling the cable and before installing it on the roof, plug the cable into a GFCI protected outlet for a few minutes to verify proper operation. Both the illuminated plug and GlowCap™ should glow, indicating the cable is receiving power. The cable should warm up to the touch within ten minutes. Unplug the cable prior to installation.

INSTALLING HEATING CABLE

1. The top of the serpentine installation pattern (the 'peaks' of the cable pattern) should extend roughly 6" beyond the intersection of the exterior wall below (Area 'A' in Figure 18.0, right)
2. Work your way across the eave by weaving the heat cable between your roof clips, which are installed roughly 24" apart from peak to peak ('D' in Figure 19.0, right). You may elect to compress that spacing under certain circumstances but keep in mind you will need more cable length to accommodate that change.
3. Valleys: Run the cable approximately 6 feet up valleys. You may elect to run the cable up further on lower sloped valleys. Remember, the NRCA currently dictates that no fasteners should be driven through the valley flashing within 6" of the centerline. See 'E' in Figure 19.0, right.
4. On areas without gutters, use Grip Clips to create a drip loop (Figure 14, page 7). On areas with gutters, you may install a single Grip Clip, point 'F' in Figure 19 or you may use no roof clips on the bottom of the pattern and use a heavy-duty UV resistant cable tie to loosely connect the bottom loop of the cable to the heat cable running along the bottom of the gutter (Figure 10, page 6).
5. Radiant Solutions Company offers a wide variety of clips for securing heat cable to just about any surface. Please consult our list of accessories on page 14 . Visit our website for more information about installing Heat Tape Pro on a wide variety of materials.
6. Gutters: Use a single run of heat cable in gutters that are 5" wide (or smaller) and two runs of cable in gutters 6" or larger. Use either downspout hangers or a CG-24 CableGuard where heat cables drop into downspouts to protect the cable from cuts and abrasions from sharp gutter edges and screws at that location (Figure 11, page 6). If a downspout is in the middle of a gutter, loop the cable down and back up. Use CableGuard to protect any areas of exposed heat cable where it exits the downspout. Where the cable enters a buried drain from the gutter system, install the cable along the entire length of the drain you wish to keep flowing in freezing conditions.
7. GlowCap™: You can install the GlowCap™ in a location to allow you to see the green indicator light easily. It can be on the roof, at the bottom of the downspout or any other location you like. If you don't wish to see the green light you can simply wrap a piece of electrical tape around GlowCap™ to cover the light.

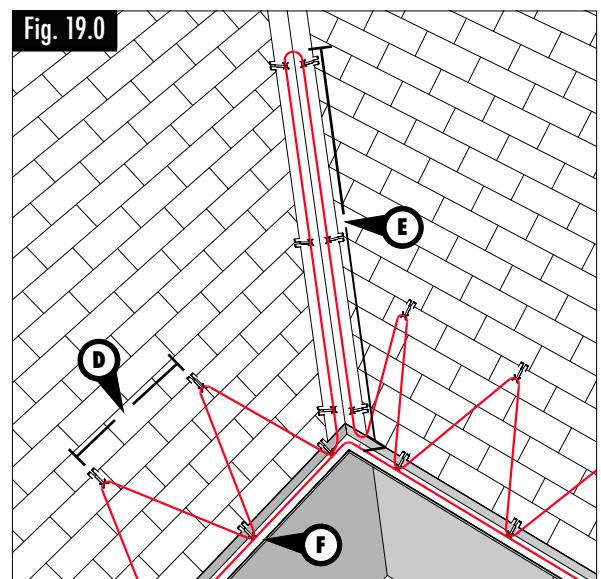
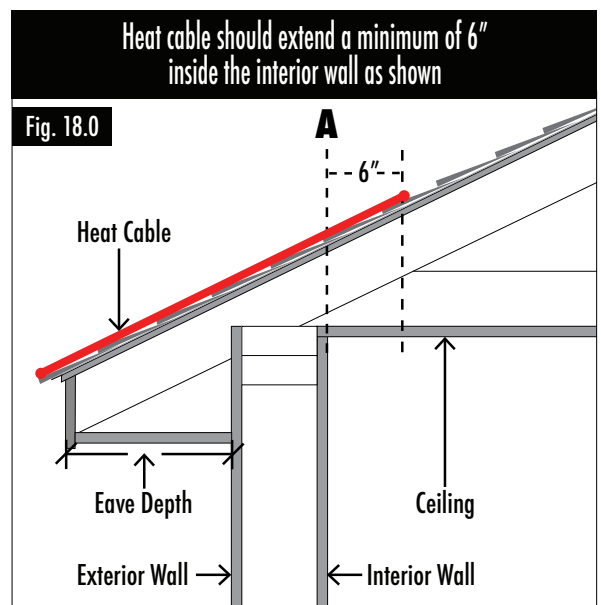

HeatTape PRO

2.5 INSTALLATION IDEAS: OTHER ACCESSORIES & METHODS

We recognize that there are many different installation scenarios you may encounter in the field. Here is a quick summary of some of the Radiant Solutions Company installation accessories in real-world scenarios. Visit our website for greater detail to determine what might work best for you.

LEO-215: StickyClip™



The patented self-adhesive StickyClip™ can be used on any non-porous material such as rubber or metal

S5-SR Clips + Standing Seam Roof Clamp



The combination of the compression-based roof clamp and our S5-SR clips is a popular choice for standing seam metal roofs

DDK-719: Jumbo Glue-Down Clips



3" x 3" Single and double cradle clips for any surface. Simply glue into position using SB-190 adhesive

Cable Guard: CG-24



Protect your expensive cable where it gets damaged most. Cable Guard is cheap insurance against costly issues

JS-222: Corrugated Metal Clip



The perfect solution for corrugated metal roofs, the JS-222 comes with self-tapping screws and sized butyl pads

Cable Guard: CG-24



Many installers prefer Cable Guard to the standard downspout hanger due to its versatility. It can be used in many ways

IDC-115: Downspout Hanger



The humble downspout hanger has long provided protection against damage to cable where it dives down into downspouts

GVG Standing Seam Clip



The GVG series comes in three widths and works well to create solid anchor points for cable on standing seam metal roofs

MPC-325: Multi-Purpose Clip



This clip can be used for many applications on asphalt shingles and sheet metal flashings. Cable can be positioned at any angle

HeatTape PRO

2.6 INSTALLATION DIAGRAMS

Here are some different installation diagrams that may help inspire your creativity with your project. Installing heat cable is as much art as science so a familiarity with the accessories and different installation options is good. These are small representations of more detailed diagrams found on our website. Please visit our website further details on all of the below.

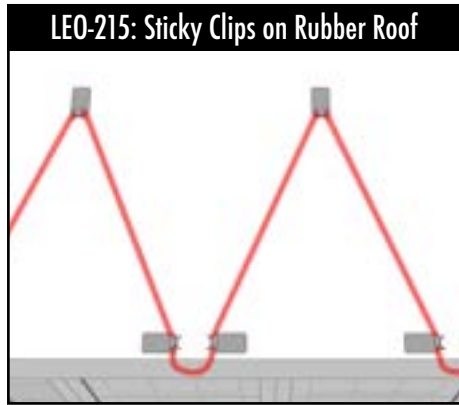

LEO-215: Sticky Clips on Rubber Roof

The StickyClip™ can be used on rubber roofs as shown. Be sure to use a ice/snow retention system above the heat cable

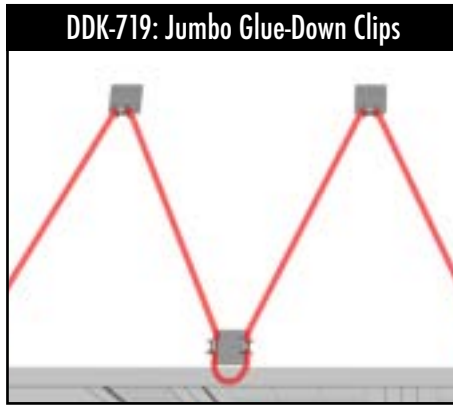

DDK-719: Jumbo Glue-Down Clips

DDK clips can be used on metal, rubber, asphalt, inside open gutters, you name it. Comes in single & double cradle options



S5-SR + Roof Clamp on Standing Seams

Example of the roof clamp plus our S5-SR clips. Notice the horizontal cable is secured with a standard IDP-113 glued to the fascia



DDK-719: Jumbo Glue Down Clips

The DDK can be used to create butterfly patterns around scuppers as illustrated. Glue down with SB-190 adhesive

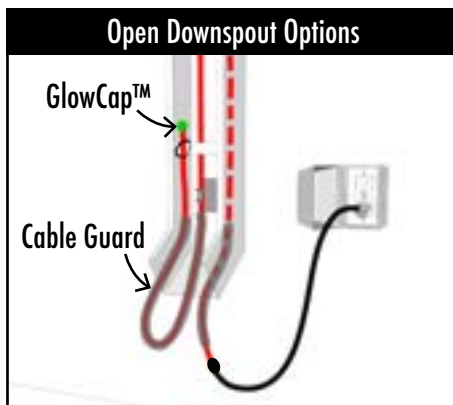

Open Downspout Options

Use Cable Guard to protect cable from sharp edges. Use a cable-tie to secure the GlowCap™ vertically for visibility



GVG Standing Seam Clips

The GVG is an affordable solution to securing cable to standing seam metal roofs as shown

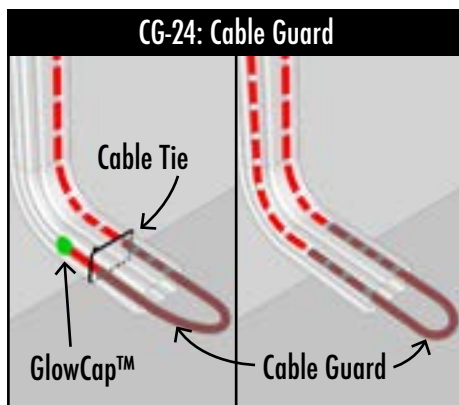

CG-24: Cable Guard

Cable is often damaged at the opening of the downspout. Use cable guard as shown to protect the cable.

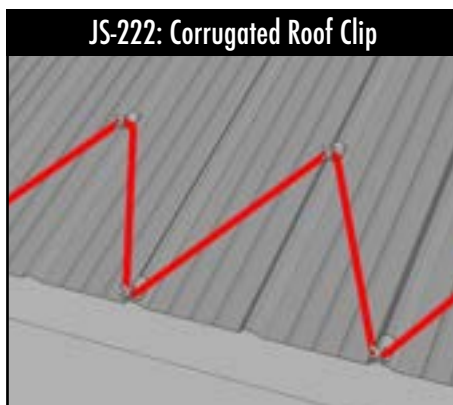

JS-222: Corrugated Roof Clip

This JS-222 works on traditional corrugated sheet metal or trapezoidal seam panels. Comes with butyl pads and screws



DDK-719: Jumbo Glue Down Clips

The DDK can be used to create star patterns around roof drains on flat and low slope roofs. Glue down with SB-190 adhesive

HeatTape PRO

2.7 HEATING CABLE SELECTION FOR PIPE FREEZE PROTECTION

Heat Tape Pro provides excellent freeze protection for pipes. Do not use Heat Tape Pro on pipes carrying anything other than water. Use the chart below to determine the appropriate cable length for your pipe freeze protection project. This chart is based on the lowest outside temperature of 0°F (-18°C) with a minimum of 1/2" thick insulation. Use 1" thick insulation to provide protection in temperatures down to -20°F (-29°C). Add 1 foot of cable length for each valve or spigot along the pipe.

Pipe Diameter	Pipe Material	LENGTH OF PIPE																							
		5'	10'	15'	20'	25'	30'	35'	40'	45'	50'	55'	60'	65'	70'	75'	80'	85'	90'	95'	100'	125'	150'	175'	200'
1/2"	Metal	6'	12'	18'	24'	37.5'	37.5'	37.5'	50'	50'	50'	62.5'	62.5'	75'	75'	75'	87.5'	87.5'	100'	100'	100'	125'	150'	175'	200'
	Plastic	6'	12'	18'	24'	37.5'	37.5'	50'	50'	50'	62.5'	62.5'	75'	75'	75'	87.5'	87.5'	100'	100'	100'	125'	150'	175'	200'	x
1"	Metal	6'	12'	18'	24'	37.5'	37.5'	37.5'	50'	50'	50'	62.5'	62.5'	75'	75'	75'	87.5'	87.5'	100'	100'	100'	125'	150'	175'	200'
	Plastic	12'	12'	18'	24'	37.5'	37.5'	50'	50'	50'	62.5'	62.5'	75'	75'	75'	87.5'	87.5'	100'	100'	100'	125'	150'	175'	200'	x
1 1/2"	Metal	6'	12'	18'	24'	37.5'	37.5'	37.5'	50'	50'	50'	62.5'	62.5'	75'	75'	75'	87.5'	87.5'	100'	100'	100'	125'	150'	175'	200'
	Plastic	12'	18'	24'	37.5'	37.5'	50'	50'	50'	62.5'	62.5'	75'	75'	75'	87.5'	87.5'	100'	100'	100'	125'	125'	175'	200'	x	x
2"	Metal	6'	12'	18'	24'	37.5'	37.5'	37.5'	50'	50'	62.5'	62.5'	75'	75'	75'	87.5'	87.5'	100'	100'	100'	125'	150'	175'	200'	x
	Plastic	12'	18'	37.5'	37.5'	50'	62.5'	75'	75'	87.5'	100'	100'	125'	125'	150'	150'	150'	175'	175'	175'	200'	x	x	x	x
2 1/2"	Metal	6'	18'	18'	24'	37.5'	50'	50'	50'	62.5'	62.5'	75'	75'	87.5'	87.5'	100'	100'	125'	125'	125'	125'	150'	200'	x	x
	Plastic	12'	24'	37.5'	50'	62.5'	75'	87.5'	100'	125'	125'	150'	150'	175'	175'	200'	200'	x	x	x	x	x	x	x	x

2.8 HEATING CABLE INSTALLATION ON PIPE

Prior to installation, check the pipe to make sure it is clean and dry. Verify the cable is the correct length, wattage and voltage prior to installation. Before any thermal insulation is installed, check the cable for proper operation and that it is free of damage such as cuts or gouges. Remove any sharp edges on the pipe that could damage the heat cable. Heat Tape Pro can be installed using a single run of cable at the 6 o'clock position on pipes that are 1" or less in diameter. On larger pipes use a double run with straight tracing at the 4 o'clock and/or 8 o'clock positions (Diagram 1.0, below). See Cable Selection Chart above for greater detail. Spiral applications use a lot of unnecessary cable and are therefore not generally recommended. Secure Heat Tape Pro to the pipe approximately every 12" using fiberglass tape (RSC-420) or nylon cable ties. Do not use duct tape, wire or vinyl tape. Do not forget to wrap valves and spigots. There is not an exact pattern that must be followed for valves, spigots or tees. Simply wrap the cable in a way that provides adequate coverage to prevent freezing. Excess cable remaining at the end of the pipe can be doubled back along the pipe. For additional thermal performance you may elect to install cable using aluminium foil tape along the entire length of the cable installation (diagram 2.0, right). This helps maintain cable-to-pipe contact and reflect heat back into the pipe. This is particularly helpful on plastic pipes because they are not as thermally conductive. Be sure to keep the cable flat as you bend it during the application.

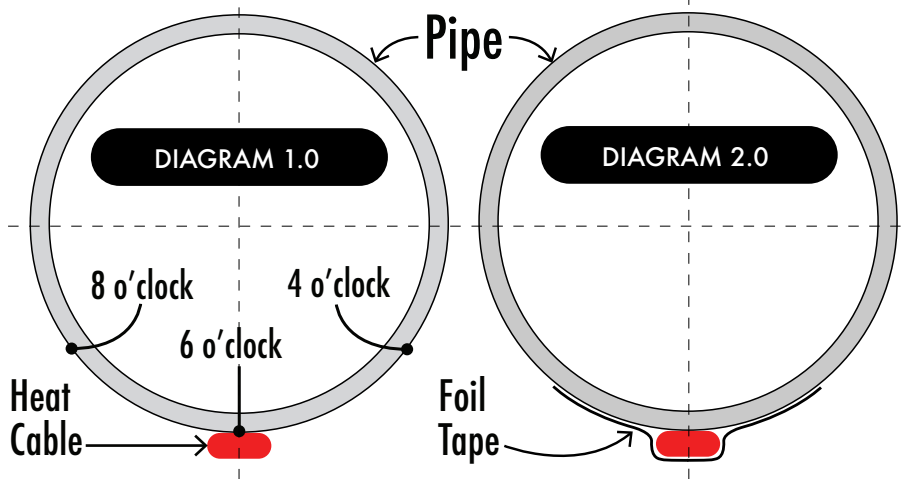

2.9 INSTALLING THERMAL INSULATION

All areas with heat cable should be covered with a minimum of 1/2" of thermal insulation. Do not leave cables exposed. For protection down to -20°F (-29°C) use 1" thick insulation. Pre-formed foam insulation or equivalent must be used on all areas that receive heat cables. Use fire resistant materials such as fiberglass tape to secure the thermal insulation on the pipes. Nylon cable ties may be used. Make sure the insulation is waterproof in all areas where the pipes are subject to exposure to water, rain or snow. Place the provided warning labels on outside of insulation where they are visible to indicate the presence of heating cable. After the cable and insulation are fully installed, turn the circuit breaker on to give power to the cable. The pipe should feel warm within one hour.



HeatTape PRO

3.0 THERMAL INSULATION CONTINUED

Here is a close-up of an ideal installation. Note that we have shown one cable on a pipe of approximately 1" diameter, located on the 4 o'clock position. The cable in this illustration should be located at the 6 o'clock. The heat cable (A) is secured to the pipe (B) with glass cloth tape (C) approximately every 12" (D). There is a continuous strip of aluminium foil tape installed (E) over that assembly. While foil tape is not required, it is a good idea for reasons previously mentioned. Once the cable(s) is secured to the pipe you must install a layer of 1/2" standard pipe insulation minimum (F). You may install thicker insulation if you like to increase energy efficiency. Finally, the pipe insulation should be secured (G) using a high-quality tape such as duct tape.

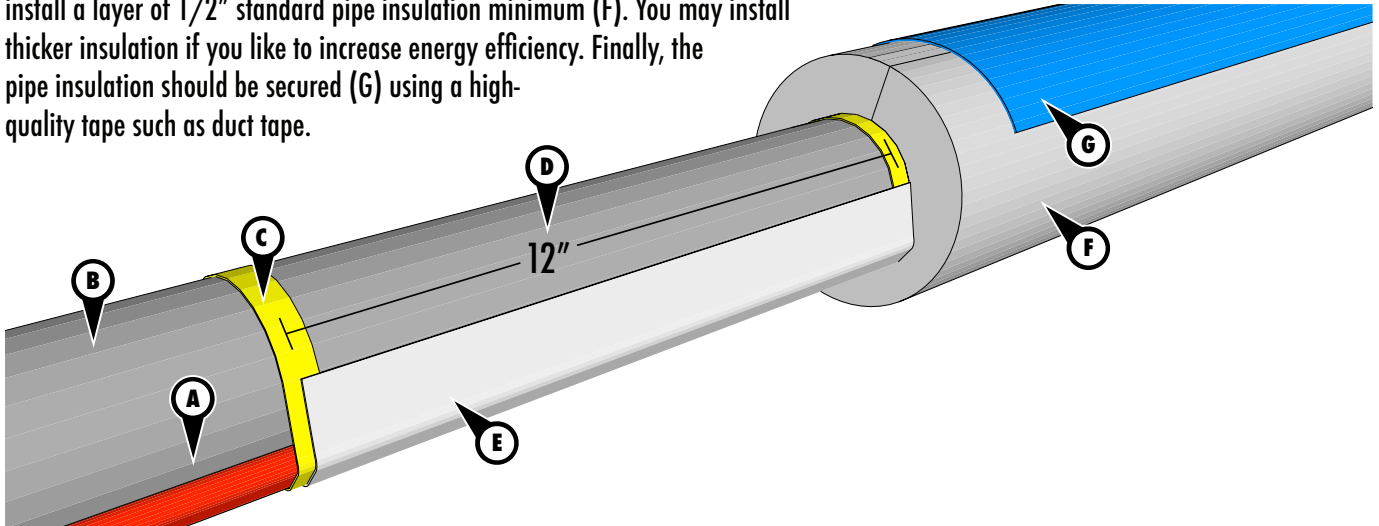

3.1 ADDITIONAL INSTALL DIAGRAM

DIAGRAM 7.0

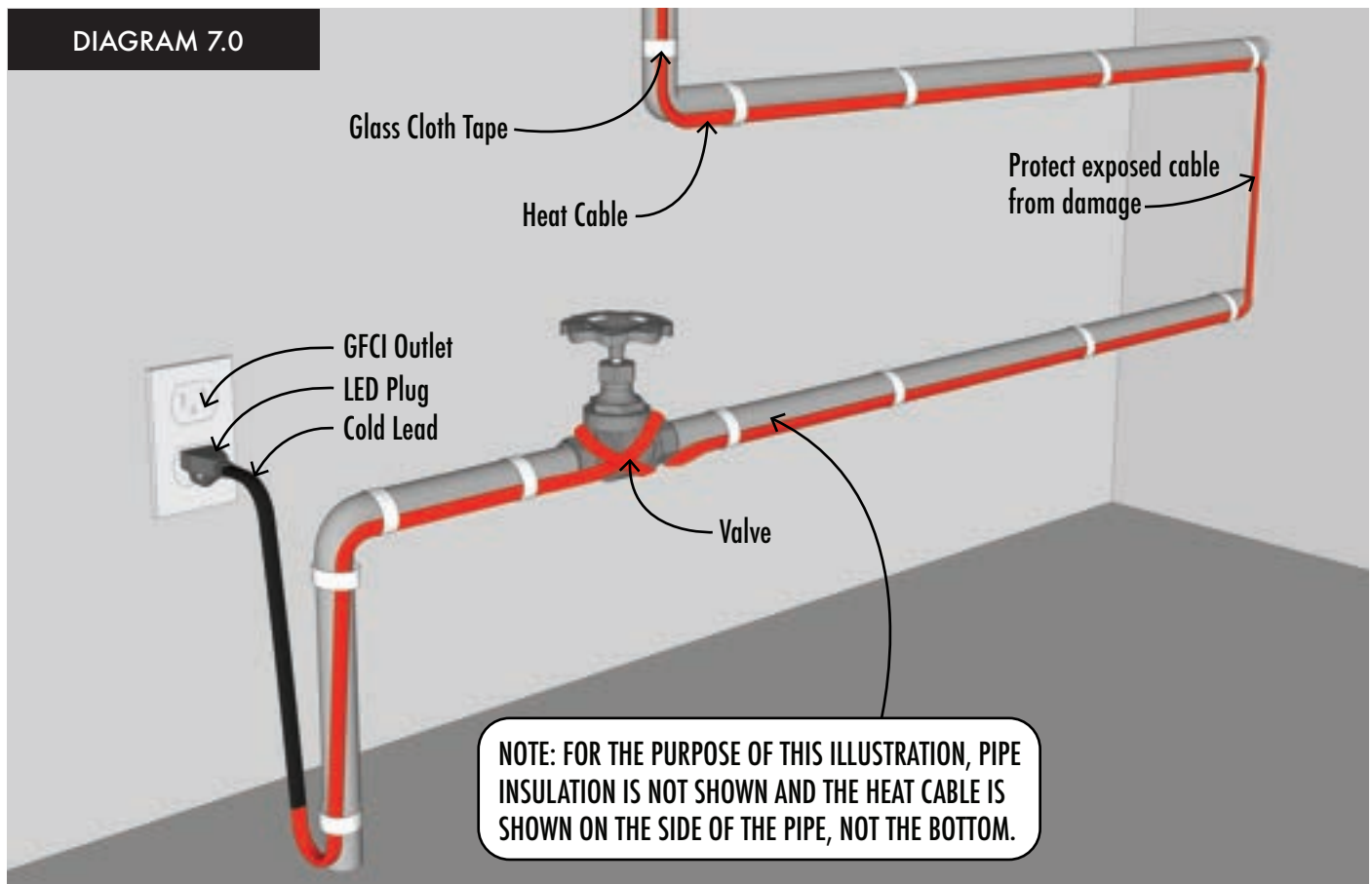









NOTE: The presence of the heating devices shall be made evident by the posting of caution signs or markings at appropriate locations and/or at frequent intervals along the circuit

HeatTape PRO

3.2 INSTALLATION ACCESSORIES

The following accessories are suitable for use with Heat Tape Pro heating cables. Use this guide to determine the most appropriate accessories for your installation. Additional installation accessories and detailed installation instructions are available at www.radiantsolutionscompany.com.

Accessories	For Use On:	Photos	
<p>Grip Clip: IDP-325, 625 & 875</p> <p>Grip Clips work with a huge variety of roofing materials including asphalt shingles, wood shakes/shingles and synthetic tile/shakes. The Patented Grip Clip is designed to install in about 5 seconds, withstand 40lbs of pull force and never threaten roof warranties. Sold in boxes of 25 in three sizes.</p> <p style="text-align: right;"><small>PATENTED</small></p>	<ul style="list-style-type: none"> Asphalt shingles of all varieties Wood shakes from .25" to .75" thick Synthetic shakes from .25" to .75" thick Certain paneled metal roof systems 		
<p>Corrugated Roof Clip: JS-222</p> <p>The body of the JS-222 is shaped to accommodate the vast majority of standard North American paneled metal roof profiles. Use the JS-222 roof clip to install heat cable on a variety of standard metal roofs including both corrugated and trapezoidal panels. The included butyl pads (MKS-1022-1) seal around the mounting screws to significantly reduce the likelihood of water ingress. Sold in boxes of 10.</p> <p style="text-align: right;"><small>PATENT PENDING</small></p>	<ul style="list-style-type: none"> Trapezoidal metal paneled roof systems Corrugated metal paneled roof systems 		
<p>Jumbo Glue-Down/Nail-Down Clips: DDK-719</p> <p>The DDK-719 Heat Cable Roof Clip can be used to secure self-regulating heat cable on a variety of roofing materials. With 200% more active surface area than traditional roof clips, the 3" x 3" DDK series offers twice the holding power in adhesive-based applications and is ideal for situations where high bond strength is desired. The DDK-719-1 has one cradle and the DDK-719-2 has two cradles. Sold in boxes of 10.</p> <p style="text-align: right;"><small>PATENT PENDING</small></p>	<ul style="list-style-type: none"> Rubber membrane TPO and PVC membranes Metal roofs Asphalt shingles of all varieties Wood shakes/shingles Synthetic shakes/shingles 		
<p>Standing Seam Saddle Clips: GVG Series</p> <p>The GVG clip comes in three sizes and is designed to provide a strong attachment point for the installation of heat cable on most common standing seam metal roofs. The GVG series will fit standing seams between 1/8" to 5/8" and when coupled with the optional MKS-1022-2 butyl pads provide an economical method of heat cable installation when compared with alternatives on the market. Model numbers: GVG-325-10 (3/8" ID), GVG-50-10 (1/2" ID) and GVG-625-10 (5/8" ID). GVG clips are sold in boxes of 10.</p> <p style="text-align: right;"><small>PATENT PENDING</small></p>	<ul style="list-style-type: none"> Standing seam metal roofs 		
<p>StickyClips: LEO-215</p> <p>The revolutionary StickyClip® is used for installing heat cable on smooth surfaces including membranes, metal roof systems, gutters, skylights, solar panels and more. The StickyClip® requires no fasteners, installs in seconds and can be removed in the future without leaving damage behind. Two standard sizes, LEO-215-1 (1.75"x1.75") and LEO-215-2 (1.75"x 3.25"). Sold in boxes of 10.</p> <p style="text-align: right;"><small>PATENTED</small></p>	<ul style="list-style-type: none"> Rubber membrane TPO and PVC membranes Metal roofs 		
<p>Multi-Purpose Clips: MPC-325</p> <p>The MPC-325 uses the patented body of the revolutionary Grip Clip™ in combination with a slotted loop and provided UV-resistant zip tie to allow for unlimited cable orientations on a variety of materials including asphalt shingles and metal flashings. This clip is a true problem solver. Sold in boxes of 10 clips with 10 zip ties. As with the standard Grip Clip™, the MPC-325 installs in seconds and requires no penetrations into the roofing system.</p> <p style="text-align: right;"><small>PATENT PENDING</small></p>	<ul style="list-style-type: none"> Asphalt shingles up to 3/8" thick Metal flashings 		
<p>Cable Guard: CG-24</p> <p>The CG-24 Cable Guard is designed to provide protection against a variety of common threats to heat cable installations including sharp metal edges, screws, abrasion and more. CG-24 is sold in 24" sections and works on cables from 8-13mm wide x 5-7mm thick. Use anywhere heat cable is exposed to potential damage to prevent premature system failure. CG-24 is frequently used in place of standard aluminium downspout hangers due to ease of installation.</p>	<ul style="list-style-type: none"> Self-regulating heat cable 8-13mm wide x 5-7mm thick 		
<p>Sized Butyl Pads: MKS-1022</p> <p>Our MKS Series butyl pads are sized specifically to accommodate the footprints of our nail-down/screw-down clips including the GVG Standing Seam Saddle Clips, the DDK Jumbo Clips and the classic Nail-down Clip. The MKS-1022-1 is 1.5" x 2" and the MKS-1022-2 is 3" x 3", both come in boxes of 10 and are about 1/8" thick.</p>	<ul style="list-style-type: none"> Roofs of any material All gutters and downspouts 		
<p>Downspout Hanger: IDP-115</p> <p>Shield your cable from the sharp-edged transition from gutter to downspout and hold your heat cable in place for maximum effectiveness in maintaining a melted pathway. The IDP-115 is made of non-corrosive aluminium and comes with 4 UV resistant cable ties. Approximate dimensions: 1" x 12".</p>	<ul style="list-style-type: none"> Gutters and other areas 		



HeatTape^{PRO}

3.3 WARRANTY

Radiant Solutions Company (the Company) warrants its electric self-regulating heat cable (the Product) to be free from defects in materials and workmanship for a period of 10 years to the first owner and/or original purchaser of the product. You must register your warranty with the company at www.radiantsolutionscompany.com within 60 days of purchase to qualify for warranty coverage. Under this Limited Warranty, Radiant Solutions Company will provide the following: If the product is determined by the Company to be defective in materials and workmanship and has not been damaged as a result of abuse, misapplication or modification, the Company will refund all or part of the manufacturer's published list price of the Product at the time of purchase. Radiant Solutions Company's maximum liability shall not in any case exceed the list price for the product claimed to be defective. Warranty requires the installation be performed in strict accordance with the details outlined in this manual. Failure to do so voids the warranty completely. Radiant Solutions Company is not responsible for damage to product it deems the result of neglect, abuse or lack of maintenance. Purchaser is responsible for the costs associated with the installation, removal and reinstallation of the products including both labor and shipping costs incurred to return the product to Radiant Solutions Company.

In order to make a warranty claim, you must:

- (a) Provide the Company with sufficient details relating to the nature of the defect, the installation, the history of operation and any repairs that may have been made. This must be done in writing within 30 days of discovery of the alleged warranty issue.
- (b) At the Company's discretion and at the owner's expense, ship the Product to the Company or the Company's local distributor.
- (c) Provide proof that the Product was installed in accordance with the applicable Product Installation Manual and any special written design or installation guidelines by Radiant Solutions Company for this project.
- (d) Provide proof that the Product was installed in accordance with the National Electrical Code (NEC) or the Canadian Electrical Code, or all applicable local building and electrical codes.
- (e) Provide a retail sales receipt or proof of purchase.
- (f) Provide a record of your cable testing and inspection.

The following are not covered by this Limited Warranty:

- (a) Any incidental or consequential damage, including inconvenience, loss of time or loss of income.
- (b) Any labor or materials required to repair or replace the Product or controls.
- (c) Any freight or delivery costs related to the Product to or from our facility.
- (d) Any costs associated with the analysis needed to discover or diagnose a potential problem with the cable system.
- (e) Radiant Solutions Company will not be responsible for consequential damages arising with respect to the product for any reason.
- (f) Any failure of the LED indicator light in the cable system (i.e., at plug or at end cap) as these are regarded as convenience features that are not relevant to the essential performance of the cable.

3.4 Troubleshooting Guide

Please review this guide before calling for technical support. Heat Tape PRO is a heavy-duty product designed to last many years under demanding conditions and 95% of the calls we receive about 'failed cables' relate to either: 1) Issues involving the power supply, and 2) Damage to the heating cable. Manufacturing defects in Heat Tape Pro are exceedingly rare. You can use the guide below to diagnose the vast majority of the problems that happen with self-regulating heat cable systems. Still stumped? Call us at 1-877-387-4218. We are here to help!

Issue	Possible Causes	Remedies
Part of cable not heating	1. Unheated area is damaged	A. Replace cable
Entire cable not generating heat	1. No or low power supply voltage	A. Check for tripped or damaged circuit breaker B. Check for damaged or faulty outlet
	2. Cable is damaged Cut in jacket is letting water into cable, cable is kinked, cable is crushed	A. Find damaged section of the heating cable and repair (if possible) B. Perform insulation resistance test with 1000vDC megometer C. Replace cable
Circuit breaker tripping	1. Circuit is overloaded	A. Remove other devices from circuit (don't have cable on a shared circuit) B. Too much cable footage on the circuit. Reduce footage of cable on circuit C. Power up cable when temperatures are above freezing D. Replace breaker if existing is undersized E. Replace circuit breakers and feed wiring per Electrical Code to accommodate heating cable footage
	2. Short circuit/damaged cable	A. Check entire cable for damage; Repair or replace cable B. Check circuit for damage; Repair as needed C. Perform insulation resistance test with 1000vDC megometer per Radiant Solutions Company recommendations D. Visually inspect entire length of heating cable for damage, which is often caused by animals or at locations such as downspout openings
	3. Defective circuit breaker	A. Replace circuit breaker
Frozen pipe	1. Cable not energizing	A. See causes and remedies above
	2. Thermal insulation issue	A. Check for damaged or wet thermal insulation - pipe must be 100% covered B. Replace or augment insulation to boost R-value
	3. Inadequate cable coverage	A. Add more heat cable: Certain circumstances, such as pipes larger than 1" in diameter, pipes with low heat conductivity (plastic) or extreme environments may require the addition of a second line of cable to provide protection against freezing
Low insulation resistance test results	1. Damaged cable or connections	A. Replace damaged heating cable. Do not try to repair a damaged area of heating cable.
Snow is covering the heat cable	1. Excessive snowfall in a short period of time	A. This is referred to as 'iglooming' and it is NOT an indication of a problem. The purpose of the heating cable is to create melted pathways through snow and ice. If the cable has even a very small margin of melted pathway through the surrounding snow and ice, the cable is operating properly
Green LED on the end of the cable is not lighting up but cable is warm	1. Defective LED	A. The LED is a convenience feature and is not required in order for the cable to operate properly. If the cable is melting pathways through snow and ice there is no corrective action to take
Cable is damaged	If your cable has sustained brand new damage and you are certain no water has gotten into the cable, you can purchase our Tee & Splice kit (TSK-723) to repair the area. If the damaged area has been exposed to any moisture, a repair will not be effective and you will have to replace your heat cable.	
Cable is not HOT	Heat Tape Pro will never get hot to the touch. It is meant only to get warm. If the cable feels warm it is working!	

HeatTape PRO

3.5 DRAWING PAD

Some people find it helpful to draw out their heat cable system plan prior to installation. Use this handy page!

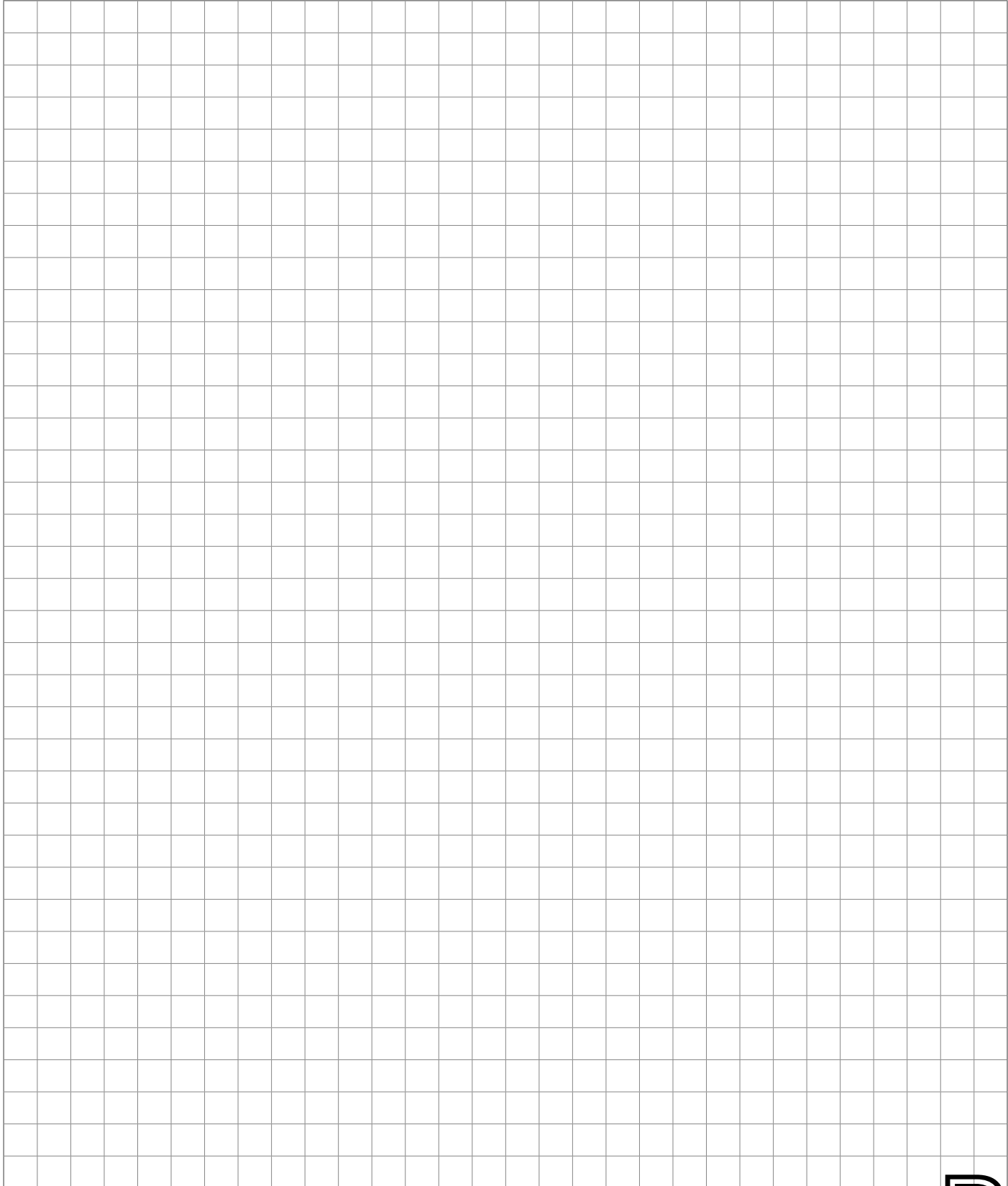



Good vibes headed your way...

Facts. Our main competitors are based in a communist country (you know the one...). Your support of our humble Minnesota business seriously means a lot to us. Your purchase not only helps buy bones for Blue but it provides security to the humans at Radiant Solutions Company too. As you would expect from your neighbors, we are here for you. If you need anything just call or write.

If you have a minute to leave us a review on Amazon or Google, that would make our day. ❤️

1515 5th Street South, Hopkins, MN 55343
Phone: 877-387-4218 radiantsolutionscompany.com