

NELSON™

AXPC100-LR/LG POWER CONNECTION KIT

INSTALLATION INSTRUCTIONS



DESCRIPTION

The AXPC100-LR/LG Power Connection Kit is designed for terminating one heater cable to customer supplied power wiring. This kit is designed for use with all wattages of CLT-J (ordinary locations), CLT-JT (ordinary locations), LT-J, LT-JT, UT-1, QLT-J, HLT-J and XLT-J heater cables. The AXPC100-RL/GL is rated IP66 - Type 4X and provides entries compatible with 3/4" (19 mm) NPT conduit entry. Standard terminal blocks are sized for maximum 6mm² (8 AWG) power wires.

These instructions are to be used together with the installation and maintenance instructions for self-regulating heater cable (GA-1765).

KIT CONTENTS

QTY	ITEM	DESCRIPTION
1	1	ENCLOSURE WITH TERMINAL BLOCKS
1	2	POWER TERMINATION
2	3	GUIDE TUBES (not shown)
1	4	END TERMINATION
1	5	SILICONE ADHESIVE
1	6	ENCLOSURE ADAPTER
1	7	RETAINER ASSEMBLY
1	8	STANDOFF
1	9	LOCKNUT
1	10	GREEN/YELLOW TUBE
1	11	PRODUCT LABEL (not shown)
1	12	CABLE TIE (not shown)
1	13	LED PILOT LIGHT
1	14	ENCLOSURE LENS ASSEMBLY

INSTALLATION ACCESSORIES

- Pipe Clamp – PC03, PC12 or PC20 (included)
- Fiberglass Tape – GT6 or GT60

OPTIONAL INSTALLATION MATERIAL

- HC-SPA Small Pipe Adapter – For 25 mm (1.0") diameter pipe and below.
- HC-TA Tank Adaptor Kit

RECOMMENDED TOOLS

- Utility Knife
- Wire Cutters
- Adjustable Wrench (52mm [2.1"] size)
- Needle Nose Pliers
- Small Flat Blade Screwdriver
- Large Slotted Screwdriver

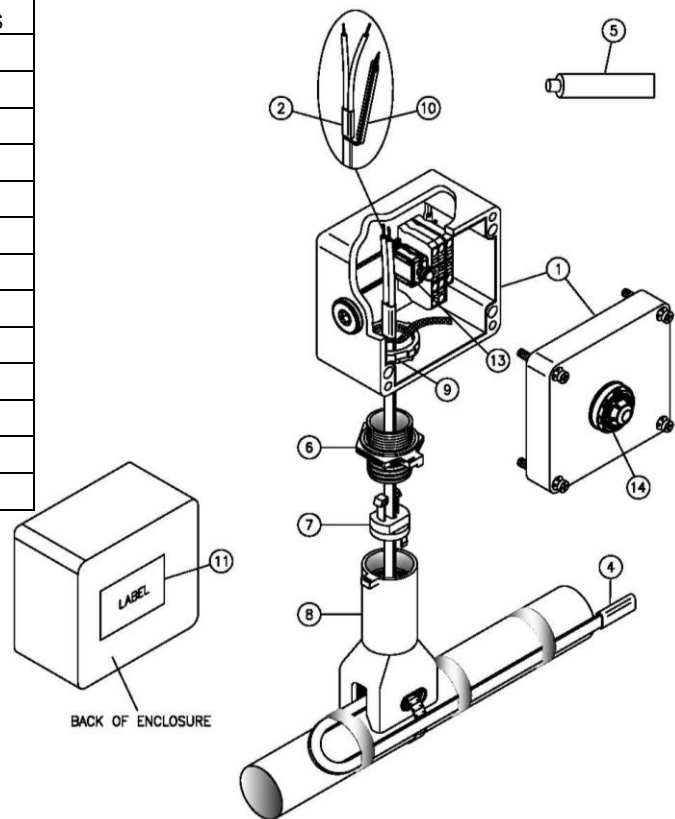

NELSON™ AXPC100-LR/LG POWER CONNECTION KIT

INSTALLATION INSTRUCTIONS

STANDOFF POSITIONING

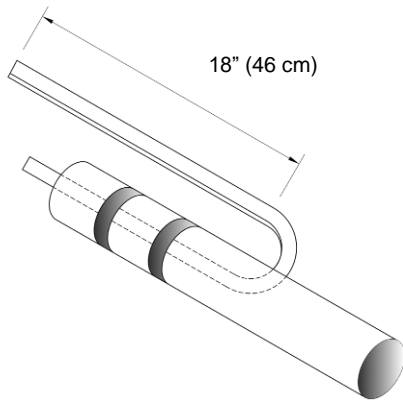

- Mark pipe where standoff will be mounted.
- Allow approximately 18" (46 cm) of heating cable for installation.
- Heating cable may be cut at a 45° angle for easier penetration.

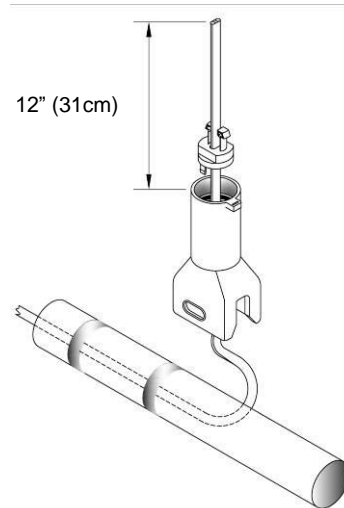

- Insert cable retainer assembled with cable grommet into standoff and clip into place.
- Insert heating cable through standoff allowing approximately 12" (31 cm) of cable for terminations.
- Use cable lubricant if necessary.
- Proceed to Heating Cable Terminations.

STEP 1

STEP 2

CABLE CONSTRUCTION DETAILS

LT / UT-1 SELF-REGULATING CABLE HLT / QLT / XLT SELF-REGULATING CABLE CLT SELF-REGULATING CABLE

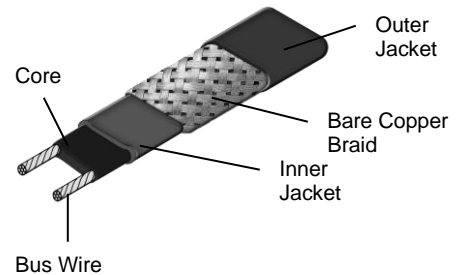
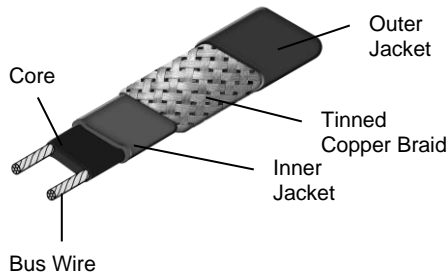
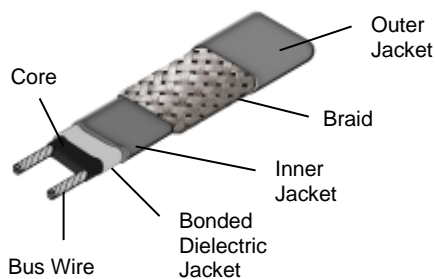

HEATING CABLE PREPARATION

- 1**
- Lightly cut around the cable outer jacket and up the center.
 - Bend cable to break outer jacket.

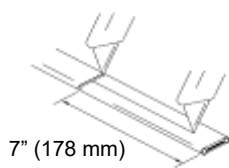

! WARNING
• Do Not Cut Braid

- 6**
- Lightly cut around the cable inner jacket.

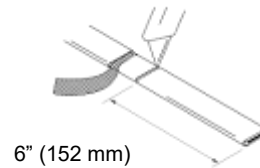

- 2**
- Remove outer jacket from heating cable.

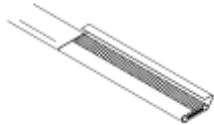

- 7**
- Cut up the middle of the inner jacket.
 - Bend cable to break inner jacket and remove.

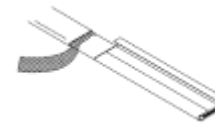

- 3**
- Push braid back to create a bulge.

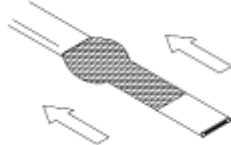

- 8**
- Shave the core material from the outside of each bus wire.

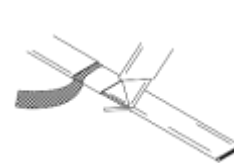

! WARNING
• Do Not Cut or Nick Bus Wires

- 4**
- At the bulge, separate the braid to make an opening.



- 9**
- Notch core material approximately 1/4" (6 mm) for the end of the heating cable.



- 5**
- Bend heating cable at opening and pull the cable through.



- 10**
- Peel both bus wires from core material.



HEATING CABLE PREPARATION

- 11**
- Lightly score core material and snap off at base of bus wires.

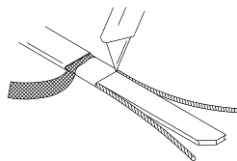

- 12**
- Trim away any frayed or damaged bus wire ends.
 - Pull braid tight to form a pigtail.



POWER TERMINATION INSTALLATION

- 1**
- Insert guide tubes into power termination fitting, if required.

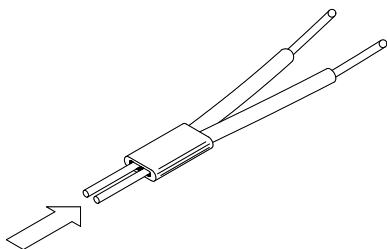

- 3**
- Remove guide tubes, if used previously.
 - Squeeze power termination opening and fill void with silicone adhesive.

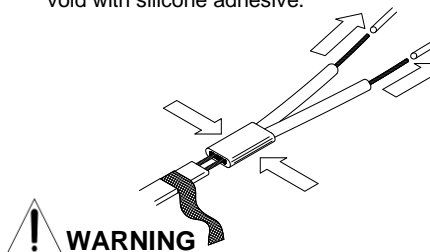

! WARNING

- Be sure that bus wires do not bunch or cross-over

- 2**
- Insert buss wires into guide tubes, if used.
 - Make sure that all buss wire strands are inserted through fitting tubes.

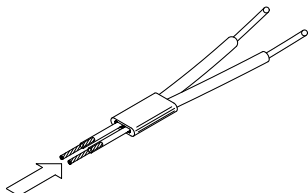

- 4**
- Push power termination to overlap jacket.
 - The silicone will set up in approximately 30 minutes with a complete cure after 24 hours.

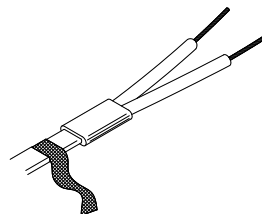

- 5**
- Slide green/yellow tubing over braid.
 - Trim bus wires and braid as necessary.

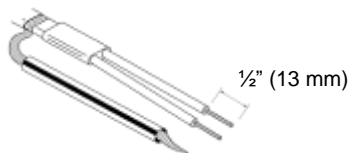

! WARNING

- Do not megger or hipot until silicone completely cured.
- Braid must be kept from bus wires or shorting may occur.

NELSON™ AXPC100-LR/LG POWER CONNECTION KIT

INSTALLATION INSTRUCTIONS

END TERMINATION INSTALLATION

1

- Lightly cut around the cable outer jacket and up the center.
- Bend cable to break outer jacket.

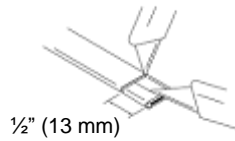

2

- Remove outer jacket from heating cable.

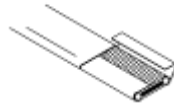

3

- Trim excess braid up to the heating cable jackets.



4

- Make a diagonal cut between bus wires.



5

- Pinch end termination body and fill void with silicone adhesive.

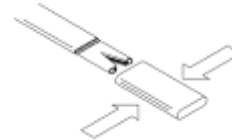

6

- Push termination firmly onto heating cable.

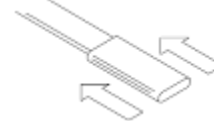

Note: The end seal is limited to exposure temperatures of 375°F (191°C). This kit, the HEC100 or HEL100 kits can be used to terminate the cable off the pipe in higher exposure temperature situations

LED LIGHT AND LENS ASSEMBLY

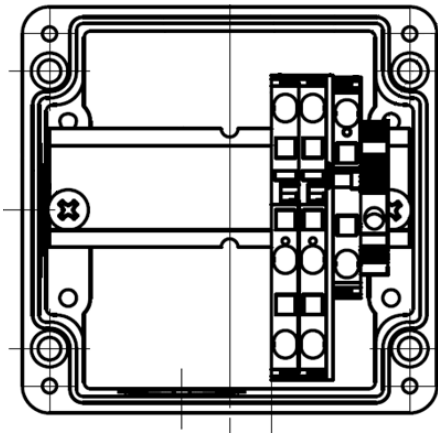

- Snap LED assembly into the notched section of the DIN rail.
- Slide terminals up against LED assembly and secure terminal end stop.

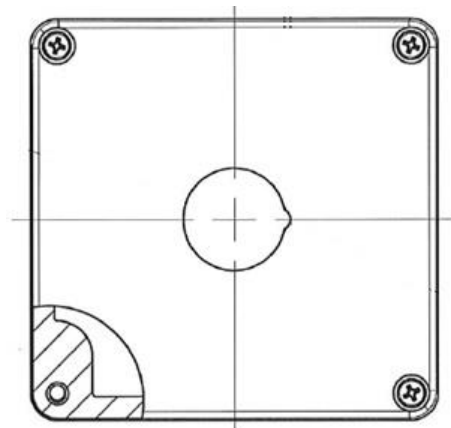

- Install lens into enclosure lid by lining up the notch in the lid with the notch on the lens assembly and secure lens assembly with supplied locknut.
- Do not over tighten locknut

NELSON™

AXPC100-LR/LG POWER CONNECTION KIT

INSTALLATION INSTRUCTIONS

FINAL ASSEMBLY

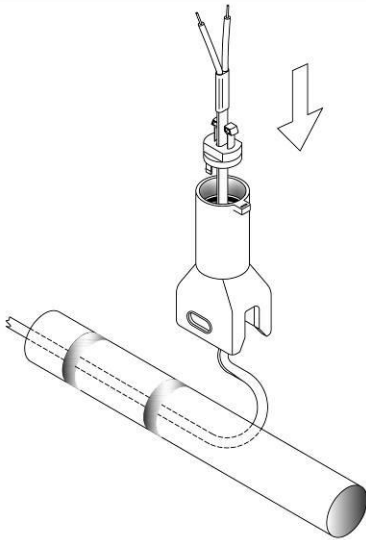

- Pull excess heating cable back through standoff.

STEP 3

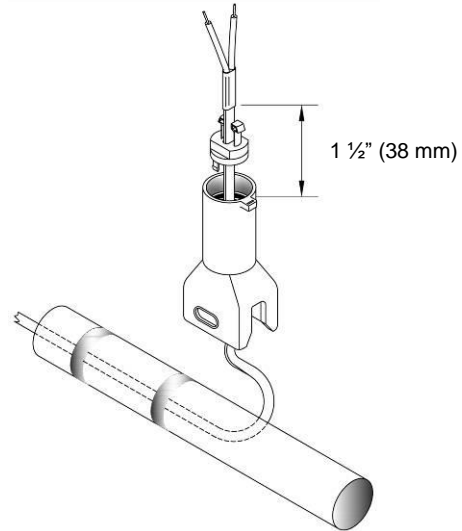

- Allow 1 1/2" (3.81 cm) of heating cable to remain above top of standoff body.

STEP 4

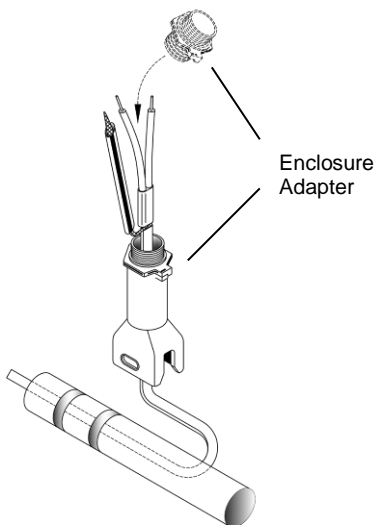

- Carefully slide enclosure adapter over cable terminations.
- Screw enclosure adapter into standoff until fully seated at positive stop.

STEP 5

Note: For pipes 1" (25mm) and below, install HC_SPA (purchased separately) between standoff and pipe.

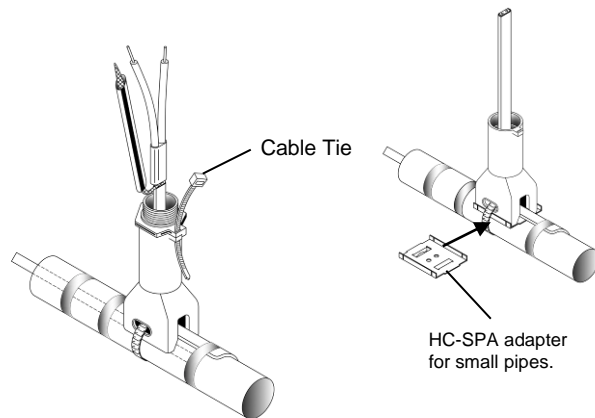

- Mount standoff securely to pipe.
- Insert supplied cable tie through slot provided to prevent possible rotation of enclosure.

STEP 6

NELSON™ AXPC100-LR/LG POWER CONNECTION KIT

INSTALLATION INSTRUCTIONS

FINAL ASSEMBLY

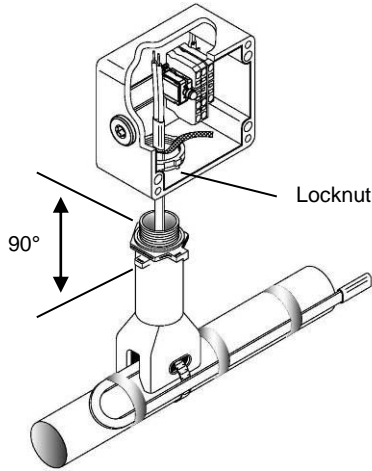

- Install enclosure and secure to enclosure adapter with supplied locknut.
- Do not over tighten locknut
- Enclosure may be rotated in 90° increments to match installation requirements.

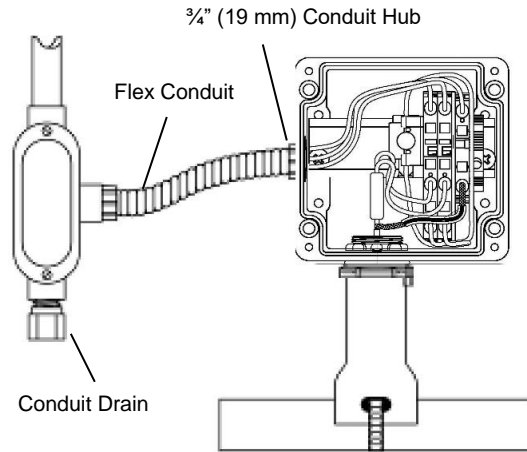

- Install flex conduit and drain as shown.
- Terminate power and ground wires to terminal block.
- Connect LED pilot light lead wires to terminal block.
- Install enclosure cover.

STEP 7



- Potential high temperature – Ensure proper selection of power cable

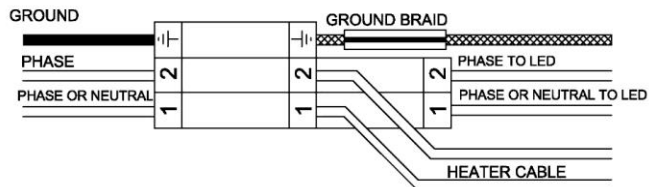

- Heating cable installations require incoming power wiring to be rated for 105°C operation.
- Maximum steady-state current may not exceed 18 amps. 25 amps for XLT cable.
- Verify that all connections are properly installed and secure.

STEP 8

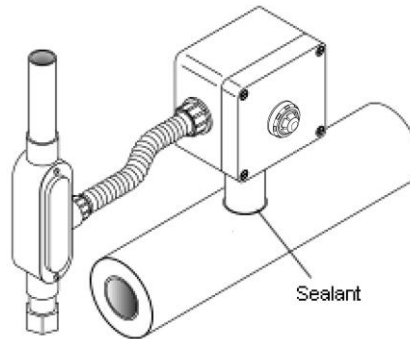

- Install thermal insulation and protective lagging.
- Apply sealant around standoff penetration to prevent moisture entry.
- Leave installation instructions with end user for future maintenance and/or trouble shooting.
- Fill in the blank fields on the label located on the cover of the junction box as follows:
CIR. NO. – Electrical circuit heating cable connected too.
CAT. NO. – Type of heating cable used
Volts – Operating voltage of heating cable – Max 277VAC
Amps – Operating current of heating cable – Max 18A continuous current. 25A for XLT cable.

ELECTRICAL WIRING

STEP 9

TEL 918-627-5530 ■ FAX 918-641-7336 ■ www.nelsonheaters.com

GENERAL CONDITIONS OF SAFE USE

- To prevent electrical arcing and fire hazard, all cable connections and electrical wiring connections should be sealed against moisture. This includes the use of proper cable sealing kits and the moisture proofing of all wire connections.
- The metal sheath/braid of the heating cable must be connected to a suitable ground path before electrical power is connected to this equipment.
- Isolate electrical power supply before opening or removing the enclosure cover.
- The enclosure cover must be secured with all screws provided to maintain the environmental ratings.
- The main components used in this connection system may present a hazard from static electricity. Only surface cleaning with a damp cloth is acceptable.
- Routine maintenance is required to maintain compliance with health and safety legislation:
 - Check that the cover gasket is in place and not damaged each time the enclosure is closed.
 - Check that all cover screws are in place and secure each time the enclosure is closed.
 - Check the security of all cable entries on a routine basis.
 - Check that all electrical connections are tight and secure on a routine basis.
 - Check for physical damage and replace as required.
- This connection system is designed for use in areas subject to normal industrial levels of vibration. They are not designed for use in areas subject to intentional or extreme conditions of vibration.
- Measures shall be taken to avoid accumulation of dust inside the standoff. This could result in unacceptable temperature rises violating the certification of the equipment.

APPROVALS

NEC®; NFPA 70: National Electrical Code®, International Electrical Code Series

IEEE Std 515™-2017 Standard for the Testing, Design, Installation, and Maintenance of Electrical Resistance Heat Tracing for Industrial Applications



Class I, Division 2, Groups ABCD;
Class II, Division 2 Groups FG;
Class III;
Encl. Type 4X, Temp. Code T*;
UL File E49805

* For temperature code see heating cable
or design information

Nelson Heat Tracing Systems products are supplied with a limited warranty. Complete Terms and Conditions may be found on Nelson's website at www.nelsonheaters.com. Nelson is a trademark of the Appleton Group LLC (Heating Cable Systems), 2 Connecticut South Dr, East Granby, CT, 06026. A division of Emerson Automation Solutions.